



Ultrasonic Cleaning

Fundamental Theory and Application

◀ [Prev](#) [Table of Contents](#) [Next](#) ▶

Abstract

A presentation describing the theory of ultrasonics and how ultrasonic technology is applied to precision cleaning. This presentation will explore the importance and application of ultrasonics in precision cleaning along with explanations of ultrasonic cleaning equipment and its application. Process parameters for ultrasonic cleaning will be discussed along with procedures for proper operation of ultrasonic cleaning equipment to achieve maximum results.

Introduction

Cleaning technology is in a state of change. Vapor degreasing using chlorinated and fluorinated solvents, long the standard for most of industry, is being phased out in the interest of the ecology of our planet. At the same time, cleaning requirements are continually increasing. Cleanliness has become an important issue in many industries where it never was in the past. In industries such as electronics where cleanliness was always important, it has become more critical in support of growing technology. It seems that each advance in technology demands greater and greater attention to cleanliness for its success. As a result, the cleaning industry has been challenged to deliver the needed cleanliness and has done so through rapid innovation over the past several years. Many of these advances have involved the use of ultrasonic technology.

The cleaning industry is currently in a struggle to replace solvent degreasing with alternative "environmentally friendly" means of cleaning. Although substitute water-based, semi-aqueous and petroleum based chemistries are available, they are often somewhat less effective as cleaners than the solvents and may not perform adequately in some applications unless a mechanical energy boost is added to assure the required levels of cleanliness. Ultrasonic energy is now used extensively in critical cleaning applications to both speed and enhance the cleaning effect of the alternative chemistries. This paper is intended to familiarize the reader with the basic theory of ultrasonics and how ultrasonic energy can be most effectively applied to enhance a variety of cleaning processes.

What is "Ultrasonics?"

Ultrasonics is the science of sound waves above the limits of human audibility. The frequency of a sound wave determines its tone or pitch. Low frequencies produce low or bass tones. High frequencies produce high or treble tones. Ultrasound is a sound with a pitch so high that it can not be heard by the human ear. Frequencies above 18 Kilohertz are usually considered to be ultrasonic. The frequencies used for ultrasonic cleaning range from 20,000

cycles per second or kilohertz (KHz) to over 100,000 KHz. The most commonly used frequencies for industrial cleaning are those between 20 KHz and 50KHz. Frequencies above 50KHz are more commonly used in small tabletop ultrasonic cleaners such as those found in jewelry stores and dental offices.



◀ Prev Table of Contents Next ▶



Ultrasonic Cleaning Fundamental Theory and Application

◀ Prev Table of Contents Next ▶

The Theory of Sound Waves

In order to understand the mechanics of ultrasonics, it is necessary to first have a basic understanding of sound waves, how they are generated and how they travel through a conducting medium. The dictionary defines sound as the transmission of vibration through an elastic medium which may be a solid, liquid, or a gas. Sound Wave Generation - A sound wave is produced when a solitary or repeating displacement is generated in a sound conducting medium, such as by a "shock" event or "vibratory" movement. The displacement of air by the cone of a radio speaker is a good example of "vibratory" sound waves generated by mechanical movement. As the speaker cone moves back and forth, the air in front of the cone is alternately compressed and rarefied to produce sound waves, which travel through the air until they are finally dissipated. We are probably most familiar with sound waves generated by alternating mechanical motion. There are also sound waves which are created by a single "shock" event. An example is thunder which is generated as air instantaneously changes volume as a result of an electrical discharge (lightning). Another example of a shock event might be the sound created as a wooden board falls with its face against a cement floor. Shock events are sources of a single compression wave which radiates from the source.

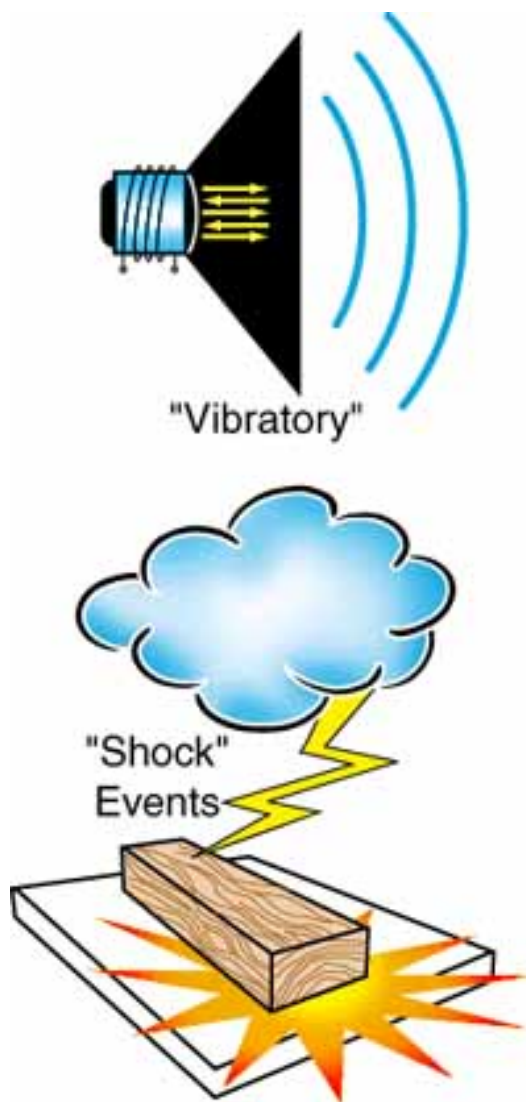



◀ Prev Table of Contents Next ▶



Ultrasonic Cleaning Fundamental Theory and Application

◀ Prev Table of Contents Next ▶

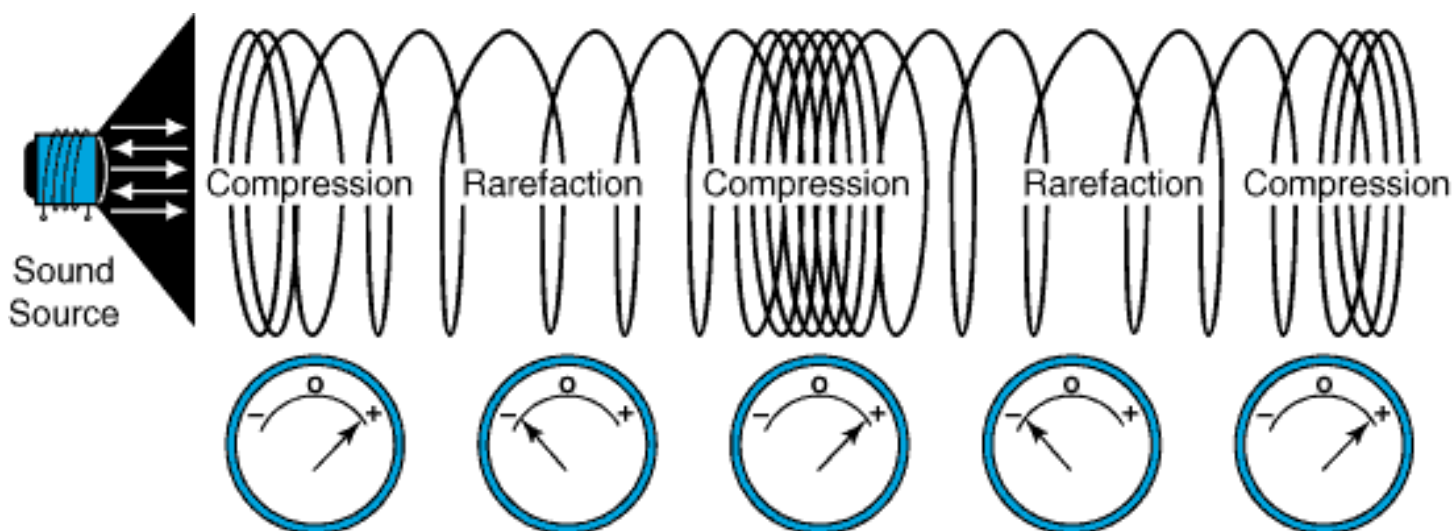

The Nature of Sound Waves

The diagram above uses the coils of a spring similar to a Slinky toy to represent individual molecules of a sound conducting medium. The molecules in the medium are influenced by adjacent molecules in much the same way that the coils of the spring influence one another. The source of the sound in the model is at the left. The compression generated by the sound source as it moves propagates down the length of the spring as each adjacent coil of the spring pushes against its neighbor. It is important to note that, although the wave travels from one end of the spring to the other, the individual coils remain in their same relative positions, being displaced first one way and then the other as the sound wave passes. As a result, each coil is first part of a compression as it is pushed toward the next coil and then part of a rarefaction as it recedes from the adjacent coil. In much the same way, any point in a sound conducting medium is alternately subjected to compression and then rarefaction. At a point in the area of a compression, the pressure in the medium is positive. At a point in the area of a rarefaction, the pressure in the medium is negative.



◀ Prev Table of Contents Next ▶



Ultrasonic Cleaning Fundamental Theory and Application

◀ Prev Table of Contents Next ▶

Cavitation and Implosion

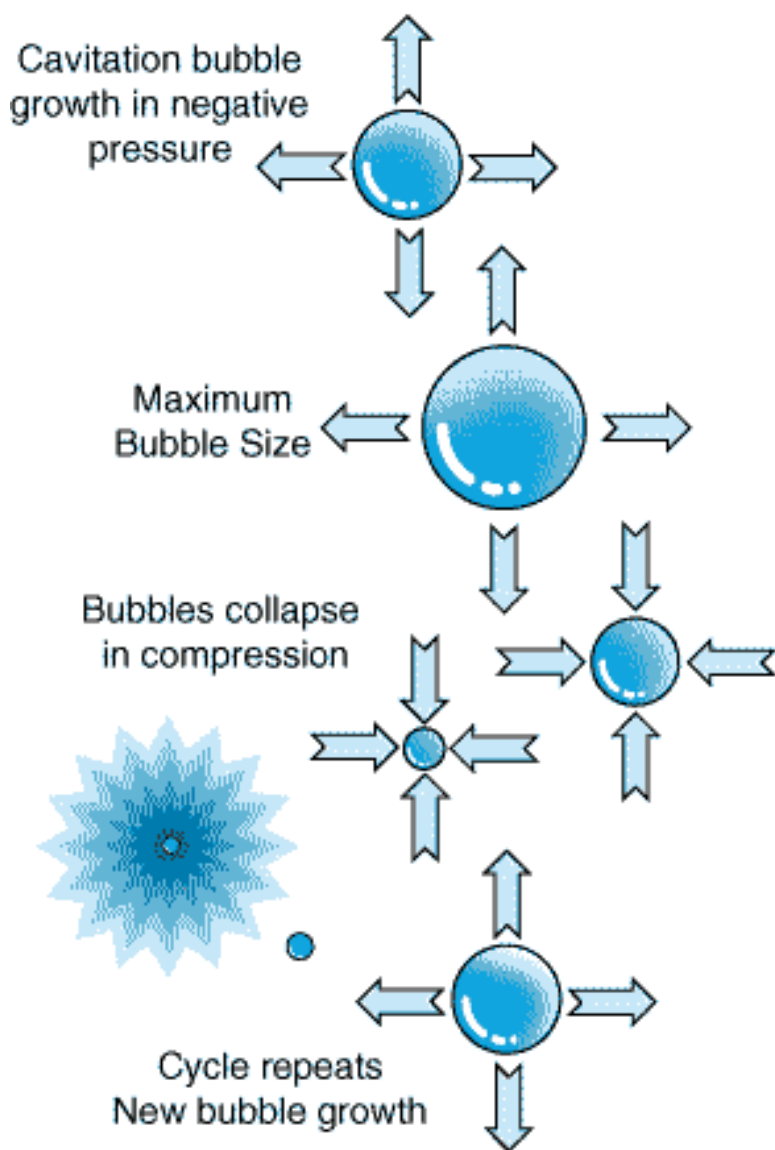

In elastic media such as air and most solids, there is a continuous transition as a sound wave is transmitted. In non-elastic media such as water and most liquids, there is continuous transition as long as the amplitude or "loudness" of the sound is relatively low. As amplitude is increased, however, the magnitude of the negative pressure in the areas of rarefaction eventually becomes sufficient to cause the liquid to fracture because of the negative pressure, causing a phenomenon known as cavitation. Cavitation "bubbles" are created at sites of rarefaction as the liquid fractures or tears because of the negative pressure of the sound wave in the liquid. As the wave fronts pass, the cavitation "bubbles" oscillate under the influence of positive pressure, eventually growing to an unstable size. Finally, the violent collapse of the cavitation "bubbles" results in implosions, which cause shock waves to be radiated from the sites of the collapse. The collapse and implosion of myriad cavitation "bubbles" throughout an ultrasonically activated liquid result in the effect commonly associated with ultrasonics. It has been calculated that temperatures in excess of 10,000°F and pressures in excess of 10,000 PSI are generated at the implosion sites of cavitation bubbles.



◀ Prev Table of Contents Next ▶



Ultrasonic Cleaning

Fundamental Theory and Application

◀ Prev Table of Contents Next ▶

Benefits of Ultrasonics in the Cleaning and Rinsing Processes

Cleaning in most instances requires that a contaminant be dissolved (as in the case of a soluble soil), displaced (as in the case of a non-soluble soil) or both dissolved and displaced (as in the case of insoluble particles being held by a soluble binder such as oil or grease). The mechanical effect of ultrasonic energy can be helpful in both speeding dissolution and displacing particles. Just as it is beneficial in cleaning, ultrasonics is also beneficial in the rinsing process. Residual cleaning chemicals are removed quickly and completely by ultrasonic rinsing.

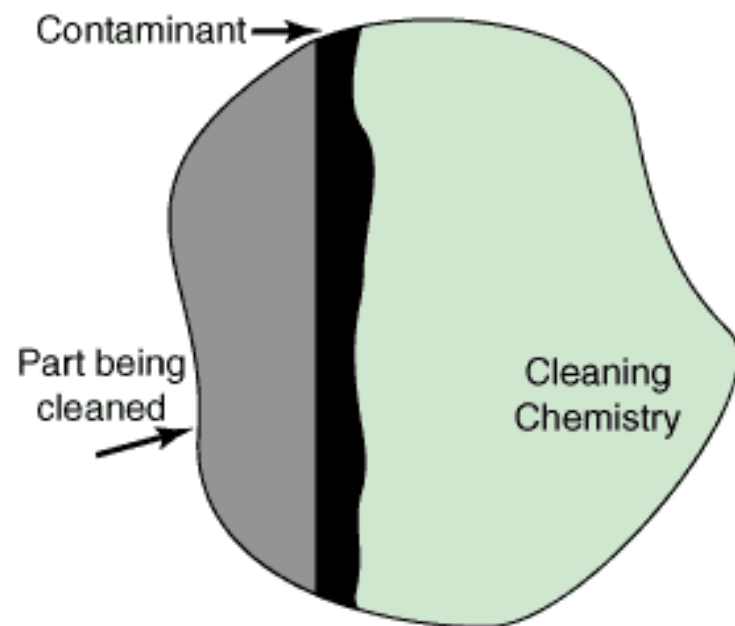

In removing a contaminant by dissolution, it is necessary for the solvent to come into contact with and dissolve the contaminant. The cleaning activity takes place only at the interface between the cleaning chemistry and the contaminant.

As the cleaning chemistry dissolves the contaminant, a saturated layer develops at the interface between the fresh cleaning chemistry and the contaminant. Once this has happened, cleaning action stops as the saturated chemistry can no longer attack the contaminant. Fresh chemistry cannot reach the contaminant.

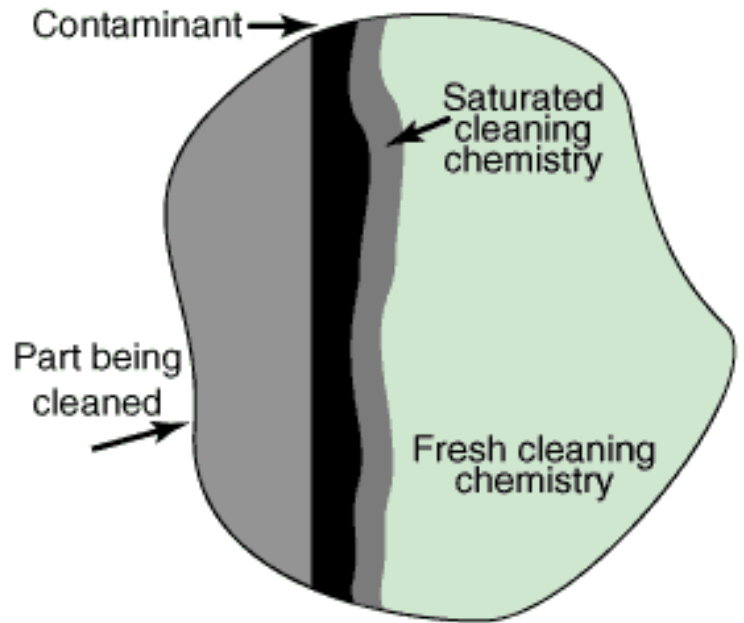
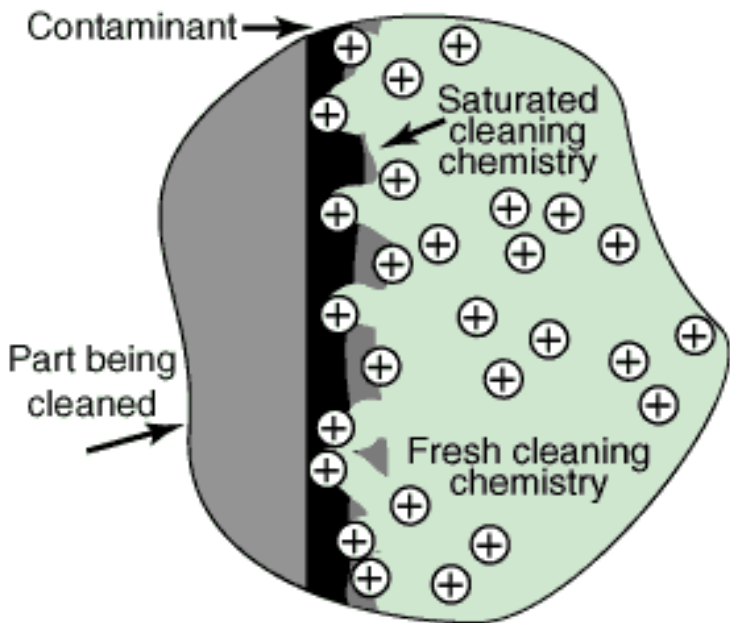

Ultrasonic cavitation and implosion effectively displace the saturated layer to allow fresh chemistry to come into contact with the contaminant remaining to be removed. This is especially beneficial when irregular surfaces or internal passageways are to be cleaned.



◀ Prev Table of Contents Next ▶



Ultrasonic Cleaning Fundamental Theory and Application

◀ Prev Table of Contents Next ▶

Ultrasonics Speeds Cleaning by Dissolution

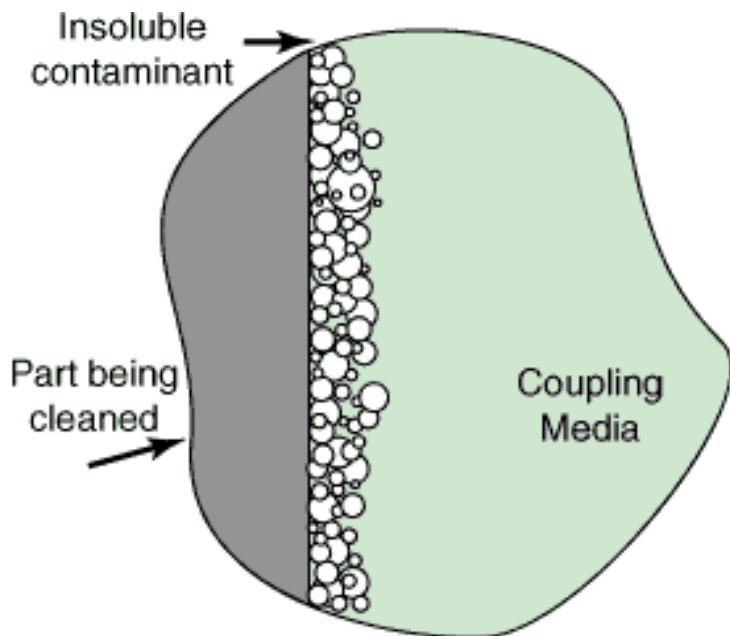

Some contaminants are comprised of insoluble particles loosely attached and held in place by ionic or cohesive forces. These particles need only be displaced sufficiently to break the attractive forces to be removed.

Cavitation and implosion as a result of ultrasonic activity displace and remove loosely held contaminants such as dust from surfaces. For this to be effective, it is necessary that the coupling medium be capable of wetting the particles to be removed.

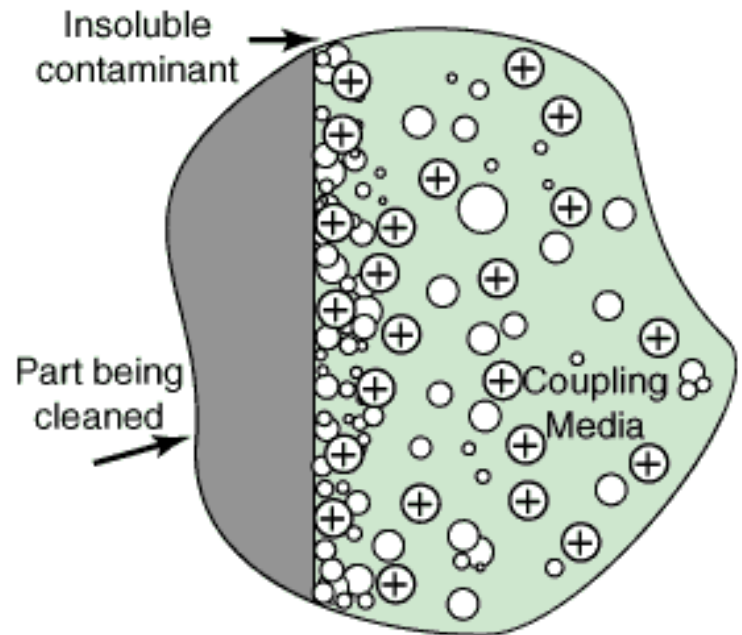

Complex Contaminants

Contaminations can also, of course, be more complex in nature, consisting of combination soils made up of both soluble and insoluble components. The effect of ultrasonics is substantially the same in these cases, as the mechanical micro-agitation helps speed both the dissolution of soluble contaminants and the displacement of insoluble particles. Ultrasonic activity has also been demonstrated to speed or enhance the effect of many chemical reactions. This is probably caused mostly by the high energy levels created as high pressures and temperatures are created at the implosion sites. It is likely that the superior results achieved in many ultrasonic cleaning operations may be at least partially attributed to the sonochemistry effect.

A Superior Process

In the above illustrations, the surface of the part being cleaned has been represented as a flat. In reality, surfaces are seldom flat, instead being comprised of hills, valleys and convolutions of all description. The illustration at the right shows why ultrasonic energy has been proven to be more effective at enhancing cleaning than other alternatives, including spray washing, brushing, turbulation, air agitation, and even electro-cleaning in many applications. The ability of ultrasonic activity to penetrate and assist the cleaning of interior surfaces of complex parts is also especially noteworthy.

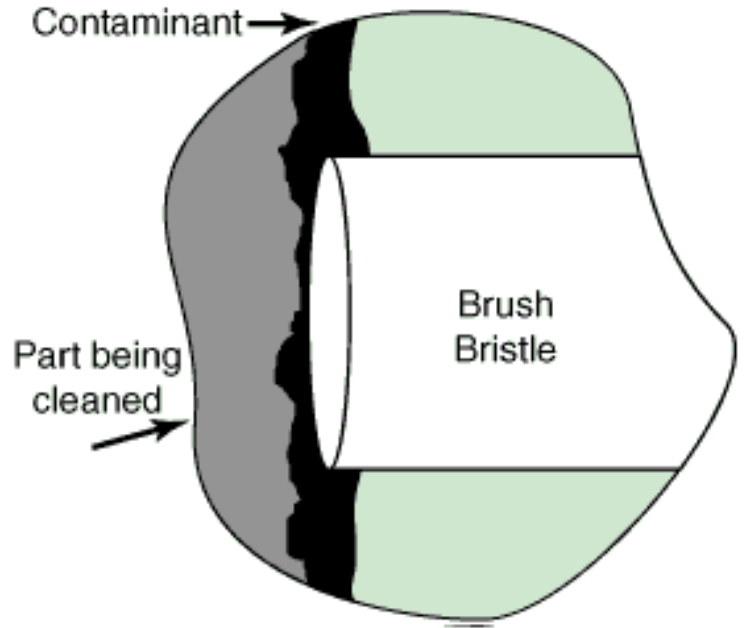

◀ Prev Table of Contents Next ▶



Ultrasonic Cleaning Fundamental Theory and Application

◀ Prev Table of Contents Next ▶

Ultrasonic Equipment

To introduce ultrasonic energy into a cleaning system requires an ultrasonic transducer and an ultrasonic power supply or "generator." The generator supplies electrical energy at the desired ultrasonic frequency. The ultrasonic transducer converts the electrical energy from the ultrasonic generator into mechanical vibrations.

Ultrasonic Generator

The ultrasonic generator converts electrical energy from the line which is typically alternating current at 50 or 60Hz to electrical energy at the ultrasonic frequency. This is accomplished in a number of ways by various equipment manufacturers. Current ultrasonic generators nearly all

use solid state technology.

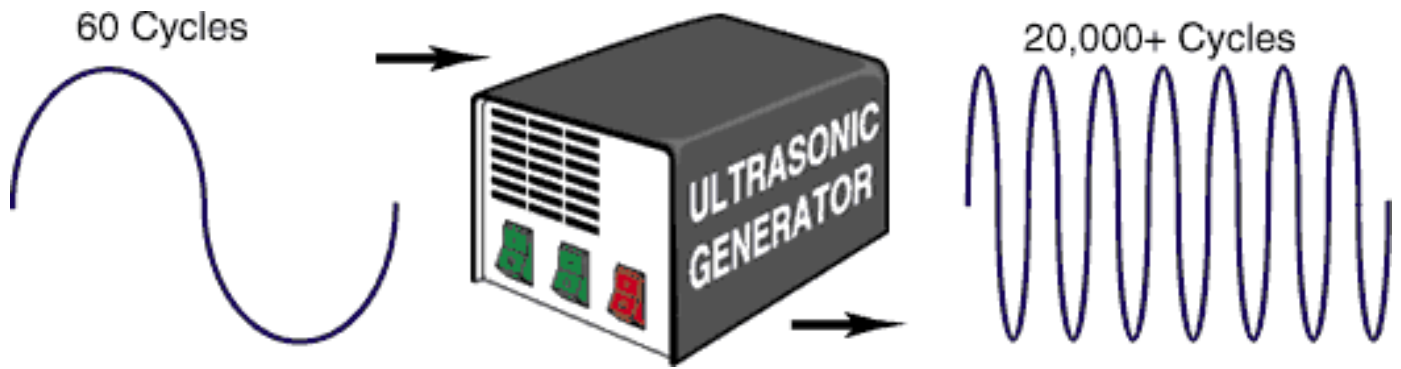

There have been several relatively recent innovations in ultrasonic generator technology which may enhance the effectiveness of ultrasonic cleaning equipment. These include square wave outputs, slowly or rapidly pulsing the ultrasonic energy on and off and modulating or "sweeping" the frequency of the generator output around the central operating frequency. The most advanced ultrasonic generators have provisions for adjusting a variety of output parameters to customize the ultrasonic energy output for the task.

Square Wave Output

Applying a square wave signal to an ultrasonic transducer results in an acoustic output rich in harmonics. The result is a multi-frequency cleaning system which vibrates simultaneously at several frequencies which are harmonics of the fundamental frequency. Multi-frequency operation offers the benefits of all frequencies combined in a single ultrasonic cleaning tank.

Pulse

In pulse operation, the ultrasonic energy is turned on and off at a rate which may vary from once every several seconds to several hundred times per second.

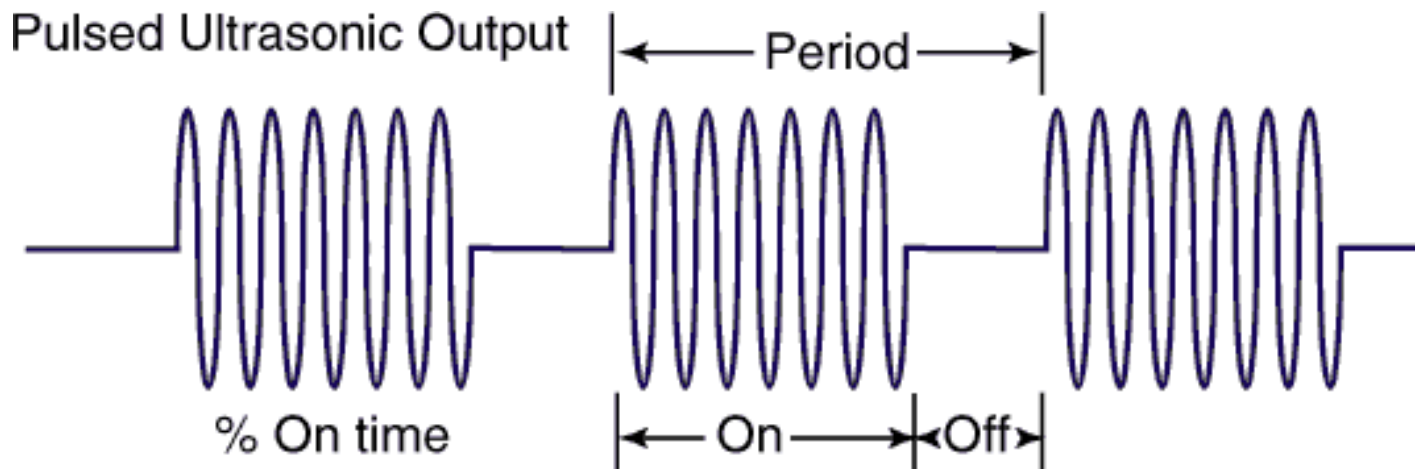

The percentage of time that the ultrasonic energy is on may also be changed to produce varied results. At slower pulse rates, more rapid degassing of liquids occurs as coalescing bubbles of air are given an opportunity to rise to the surface of the liquid during the time the ultrasonic energy is off. At more rapid pulse rates the cleaning process may be enhanced as repeated high energy "bursts" of ultrasonic energy occur each time the energy source is turned on.



◀ Prev Table of Contents Next ▶



Ultrasonic Cleaning Fundamental Theory and Application

◀ Prev Table of Contents Next ▶

Frequency Sweep

In sweep operation, the frequency of the output of the ultrasonic generator is modulated around a central frequency which may itself be adjustable.

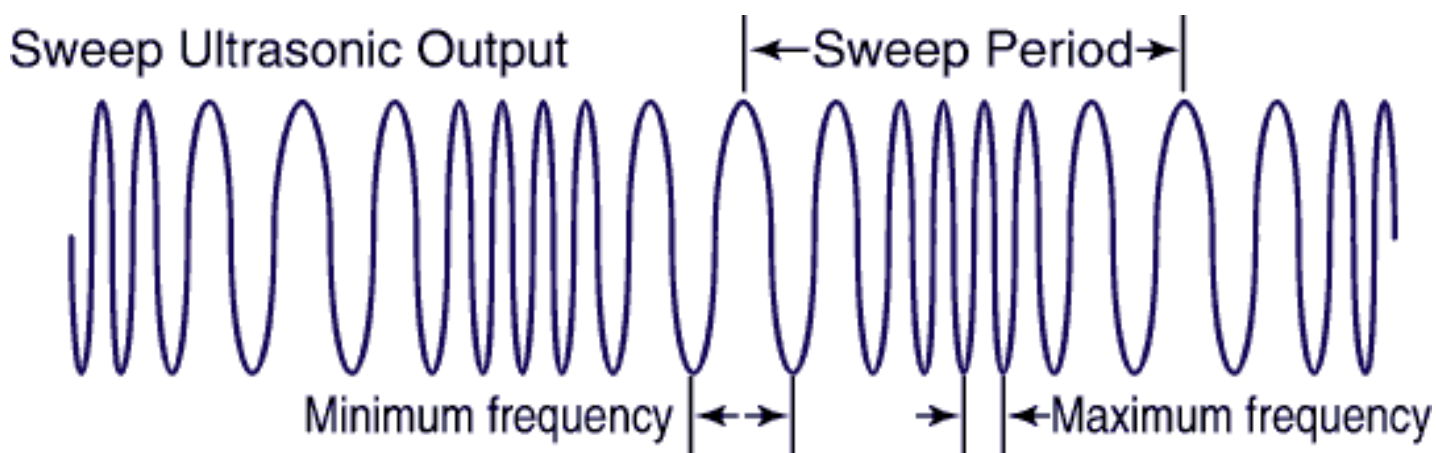

Various effects are produced by changing the speed and magnitude of the frequency modulation. The frequency may be modulated from once every several seconds to several hundred times per second with the magnitude of variation ranging from several hertz to several kilohertz. Sweep may be used to prevent damage to extremely delicate parts or to reduce the effects of standing waves in cleaning tanks. Sweep operation may also be found especially useful in facilitating the cavitation of terpenes and petroleum based chemistries. A combination of Pulse and sweep operation may provide even better results when the cavitation of terpenes and petroleum based chemistries is required.

Frequency and Amplitude

Frequency and amplitude are properties of sound waves. The illustrations below demonstrate frequency and amplitude using the spring model introduced earlier. In the diagram, if **A** is the base sound wave, **B** with less displacement of the media (less intense compression and rarefaction) as the wave front passes, represents a sound wave of less amplitude or "loudness." **C** represents a sound wave of higher frequency indicated by more wave fronts passing a given point within a given period of time.

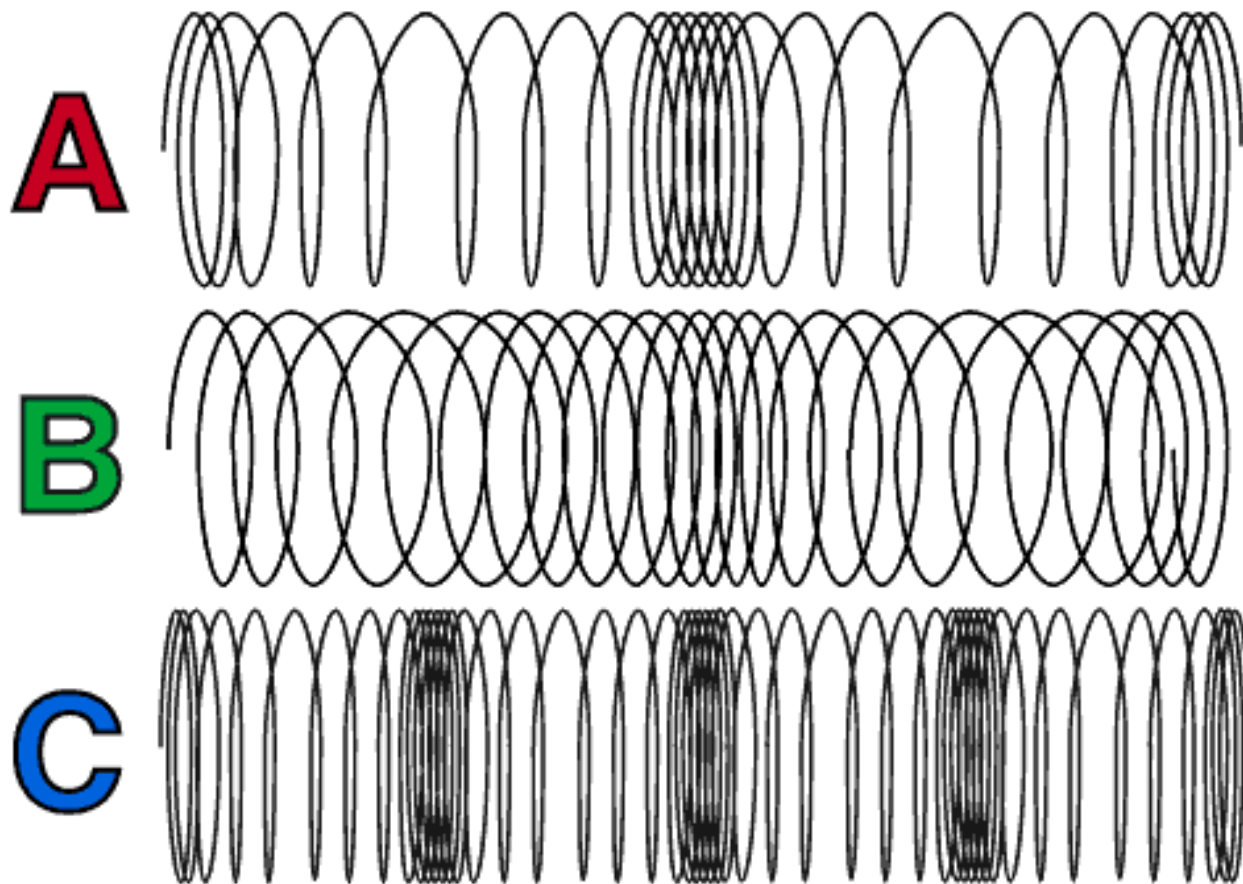



[◀ Prev Table of Contents Next ▶](#)



Ultrasonic Cleaning Fundamental Theory and Application

[◀ Prev Table of Contents Next ▶](#)

Ultrasonic Transducers

There are two general types of ultrasonic transducers in use today: Magnetostrictive and piezoelectric. Both accomplish the same task of converting alternating electrical energy to vibratory mechanical energy but do it through the use of different means.

Magnetostrictive

Magnetostrictive transducers utilize the principle of magnetostriction in which certain materials expand and contract when placed in an alternating magnetic field.

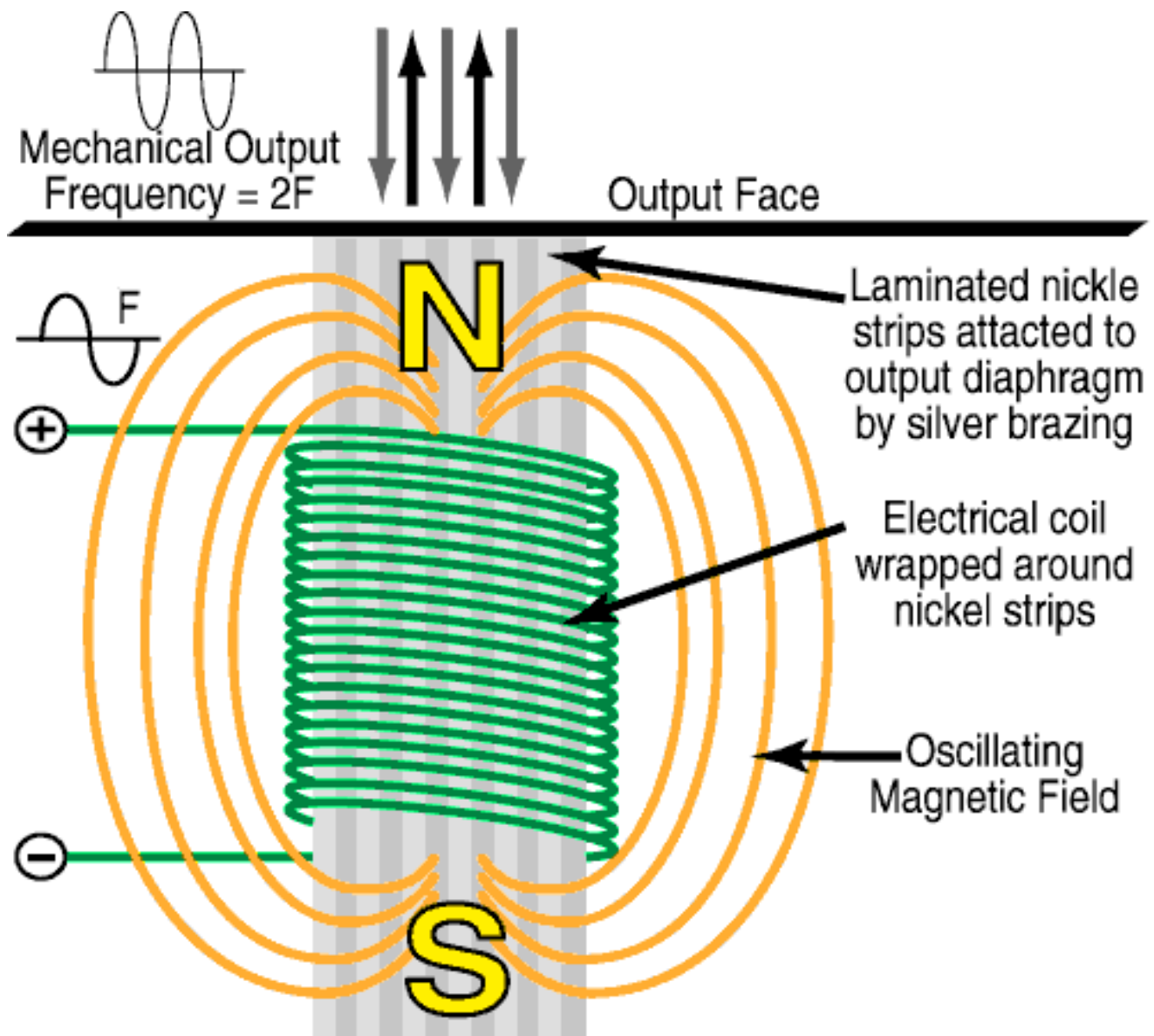

Alternating electrical energy from the ultrasonic generator is first converted into an alternating magnetic field through the use of a coil of wire. The alternating magnetic field is then used to induce mechanical vibrations at the ultrasonic frequency in resonant strips of nickel or other magnetostrictive material which are attached to the surface to be vibrated. Because magnetostrictive materials behave identically to a magnetic field of either polarity, the frequency of the electrical energy applied to the transducer is 1/2 of the desired output frequency. Magnetostrictive transducers were first to supply a robust source of ultrasonic vibrations for high power applications such as ultrasonic cleaning.

Because of inherent mechanical constraints on the physical size of the hardware as well as electrical and magnetic complications, high power magnetostrictive transducers seldom operate at frequencies much above 20 kilohertz. Piezoelectric transducers, on the other hand, can easily operate well into the megahertz range.

Magnetostrictive transducers are generally less efficient than their piezoelectric counterparts. This is due primarily to the fact that the magnetostrictive transducer requires a dual energy conversion from electrical to magnetic and then from magnetic to mechanical. Some efficiency is lost in each conversion. Magnetic hysteresis effects also detract from the

efficiency of the magnetostrictive transducer.



[◀ Prev Table of Contents Next ▶](#)



Ultrasonic Cleaning Fundamental Theory and Application

[◀ Prev Table of Contents Next ▶](#)

Piezoelectric

Piezoelectric transducers convert alternating electrical energy directly to mechanical energy through use of the piezoelectric effect in which certain materials change dimension when an electrical charge is applied to them.

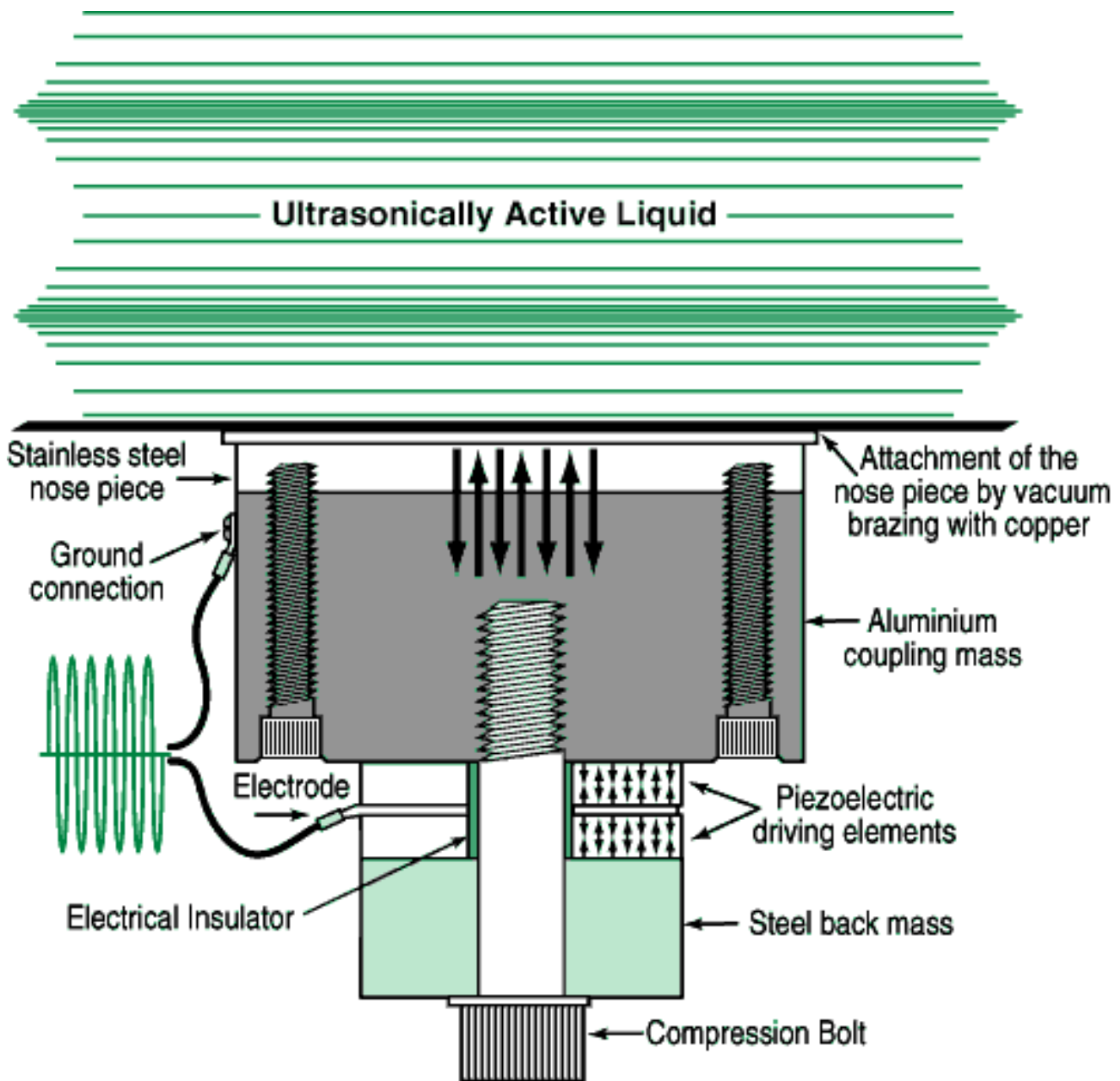

Electrical energy at the ultrasonic frequency is supplied to the transducer by the ultrasonic generator. This electrical energy is applied to piezoelectric element(s) in the transducer which vibrate. These vibrations are amplified by the resonant masses of the transducer and directed into the liquid through the radiating plate. Early piezoelectric transducers utilized such piezoelectric materials as naturally occurring quartz crystals and barium titanate which were fragile and unstable. Early piezoelectric transducers were, therefore, unreliable. Today's transducers incorporate stronger, more efficient and highly stable ceramic piezoelectric materials which were developed as a result of the efforts of the US Navy and its research to develop advanced sonar transponders in the 1940's. The vast majority of transducers used today for ultrasonic cleaning utilize the piezoelectric effect.



◀ Prev Table of Contents Next ▶



Ultrasonic Cleaning Fundamental Theory and Application

◀ Prev Table of Contents Next ▶

Ultrasonic Cleaning Equipment

Ultrasonic cleaning equipment ranges from the small tabletop units often found in dental offices or jewelry stores to huge systems with capacities of several thousand gallons used in a variety of industrial applications. Selection or design of the proper equipment is paramount in the success of any ultrasonic cleaning application.

The simplest application may require only a simple heated tank cleaner with rinsing to be done in a sink or in a separate container. More sophisticated cleaning systems include one or more rinses, added process tanks and hot air dryers. Automation is often added to reduce labor and guarantee process consistency.

The largest installations utilize immersible ultrasonic transducers which can be mounted on the sides or bottom of cleaning tanks of nearly any size. Immersible ultrasonic transducers offer maximum flexibility and ease of installation and service.

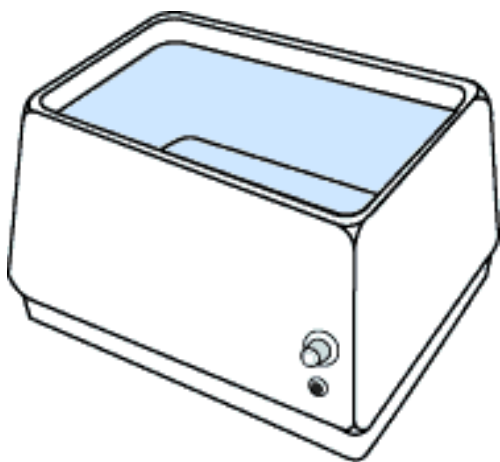

Small, self-contained cleaners are used in doctors' offices and jewelry stores.

Heated tank cleaning systems are used in laboratories and for small

batch cleaning needs.

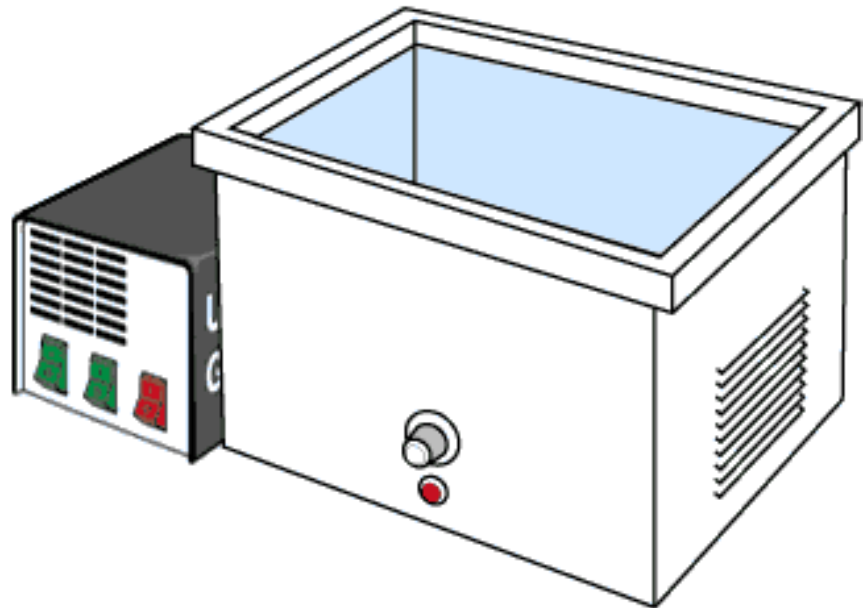

◀ Prev Table of Contents Next ▶



Ultrasonic Cleaning Fundamental Theory and Application

◀ Prev Table of Contents Next ▶

Ultrasonic Cleaning Equipment *cont.*

Console cleaning systems integrate ultrasonic cleaning tank(s), rinse tank(s) and a dryer for batch cleaning. Systems can be automated through the use of a PLC controlled material handling system.

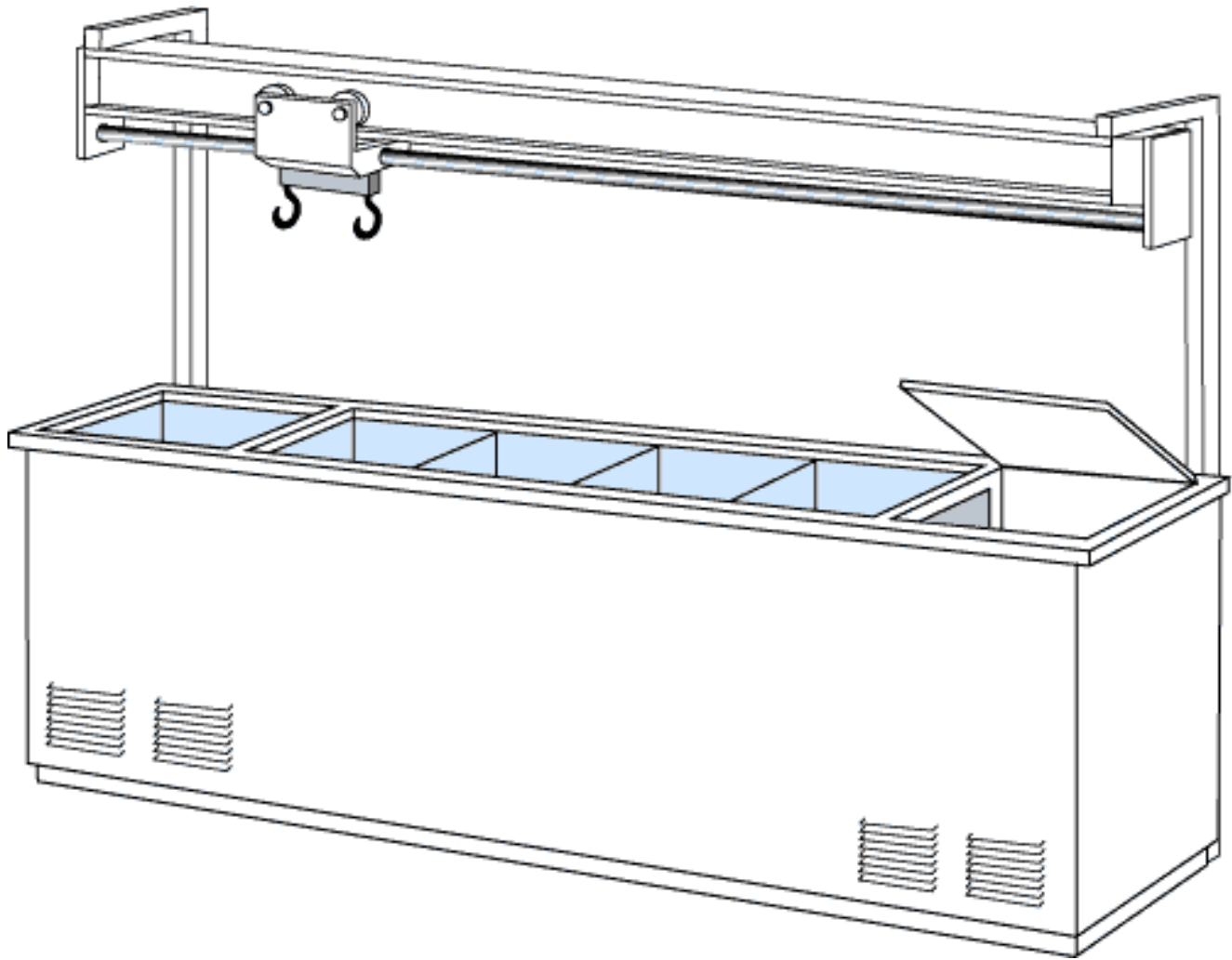

A wide range of options may be offered in custom designed systems. Large scale installations or retrofitting of existing tanks in plating lines, etc., can be achieved through the use of modular immersible ultrasonic transducers. Ultrasonic generators are often housed in climate-controlled enclosures.

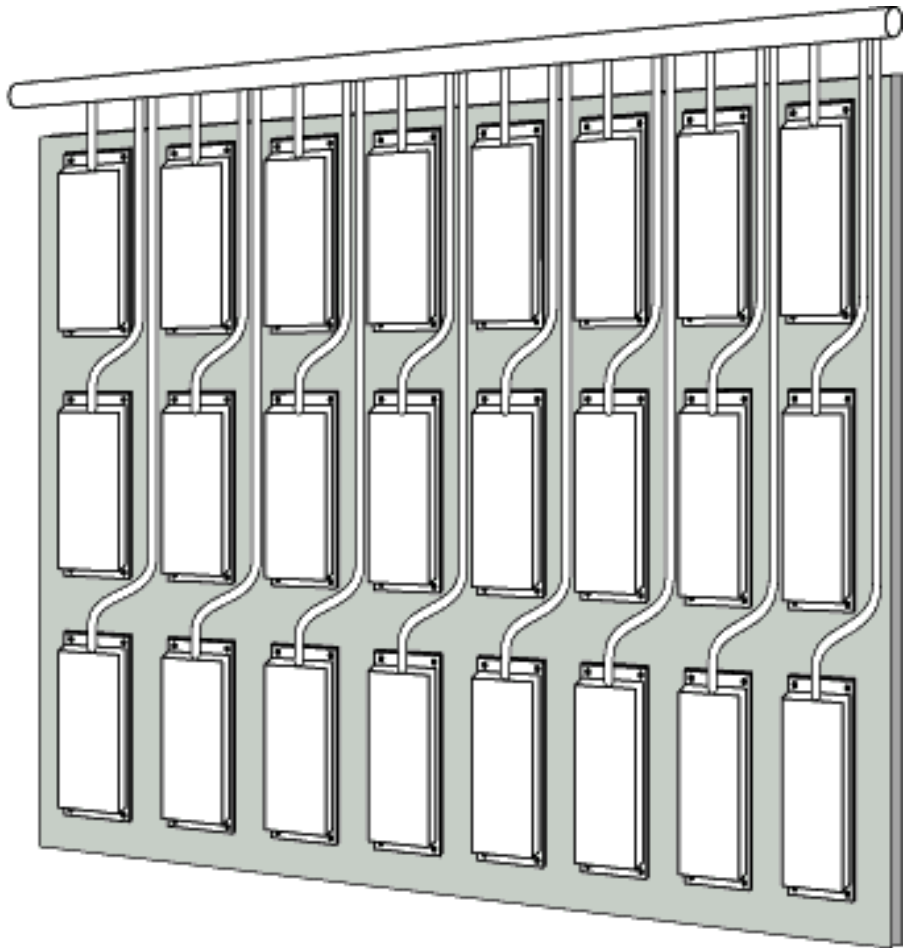
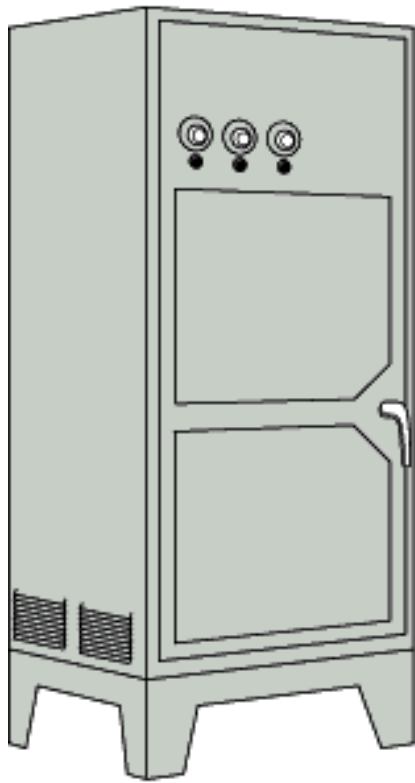

◀ Prev Table of Contents Next ▶



Ultrasonic Cleaning Fundamental Theory and Application

◀ Prev Table of Contents Next ▶

Maximizing the Ultrasonic Cleaning Process

Process Parameters

Effective application of the ultrasonic cleaning process requires consideration of a number of parameters. While time, temperature and chemical remain important in ultrasonic cleaning as they are in other cleaning technologies, there are other factors which must be considered to maximize the effectiveness of the process. Especially important are those variables which affect the intensity of ultrasonic cavitation in the liquid.

Maximizing Cavitation

Maximizing cavitation of the cleaning liquid is obviously very important to the success of the ultrasonic cleaning process. Several variables affect cavitation intensity.

Temperature is the most important single parameter to be considered in maximizing cavitation intensity. This is because so many liquid properties affecting cavitation intensity are related to temperature. Changes in temperature result in changes in viscosity, the solubility of gas in the liquid, the diffusion rate of dissolved gasses in the liquid, and vapor pressure, all of which affect cavitation intensity. In pure water, the cavitation effect is maximized at approximately 160°F.

The viscosity of a liquid must be minimized for maximum cavitation effect. Viscous liquids are sluggish and cannot respond quickly enough to form cavitation bubbles and violent implosion. The viscosity of most liquids is reduced as temperature is increased.

For most effective cavitation, the cleaning liquid must contain as little dissolved gas as possible. Gas dissolved in the liquid is released during the bubble growth phase of cavitation and prevents its violent implosion which is required for the desired ultrasonic effect. The amount of dissolved gas in a liquid is reduced as the liquid temperature is increased.

The diffusion rate of dissolved gasses in a liquid is increased at higher temperatures. This means that liquids at higher temperatures give up dissolved gasses more readily than those at lower temperatures, which aids in minimizing the amount of dissolved gas in the liquid.

A moderate increase in the temperature of a liquid brings it closer to its vapor pressure, meaning that vaporous cavitation is more easily achieved. Vaporous cavitation, in which the cavitation bubbles are filled with the vapor of the cavitating liquid, is the most effective form of cavitation. As the boiling temperature is approached, however, the cavitation intensity is reduced as the liquid starts to boil at the cavitation sites.

Cavitation intensity is directly related to **Ultrasonic Power** at the power levels generally used in ultrasonic cleaning systems. As power is increased substantially above the cavitation threshold, cavitation intensity levels off and can only be further increased through the use of focusing techniques.

Cavitation intensity is inversely related to **Ultrasonic Frequency**. As the ultrasonic frequency is increased, cavitation intensity is reduced because of the smaller size of the cavitation bubbles and their resultant less violent implosion. The reduction in cavitation effect at higher frequencies may be overcome by increasing the ultrasonic power.



[◀ Prev Table of Contents Next ▶](#)



Ultrasonic Cleaning Fundamental Theory and Application

[◀ Prev Table of Contents Next ▶](#)

Importance of Minimizing Dissolved Gas

During the negative pressure portion of the sound wave, the liquid is torn apart and cavitation bubbles start to form. As a negative pressure develops within the bubble, gasses dissolved in the cavitating liquid start to diffuse across the boundary into the bubble. As negative pressure is reduced due to the passing of the rarefaction portion of the sound wave and atmospheric pressure is reached, the cavitation bubble starts to collapse due to its own surface tension. During the compression portion of the sound wave, any gas which diffused into the bubble is compressed and finally starts to diffuse across the boundary again to re-enter the liquid. This process, however, is never complete as long as the bubble contains gas since the diffusion out of the bubble does not start until the bubble is compressed. And once the bubble is compressed, the boundary surface available for diffusion is reduced. As a result, cavitation bubbles formed in liquids containing gas do not collapse all the way to implosion but rather result in a small pocket of compressed gas in the liquid. This phenomenon can be useful in degassing liquids.

The small gas bubbles group together until they finally become sufficiently buoyant to come to the surface of the liquid.

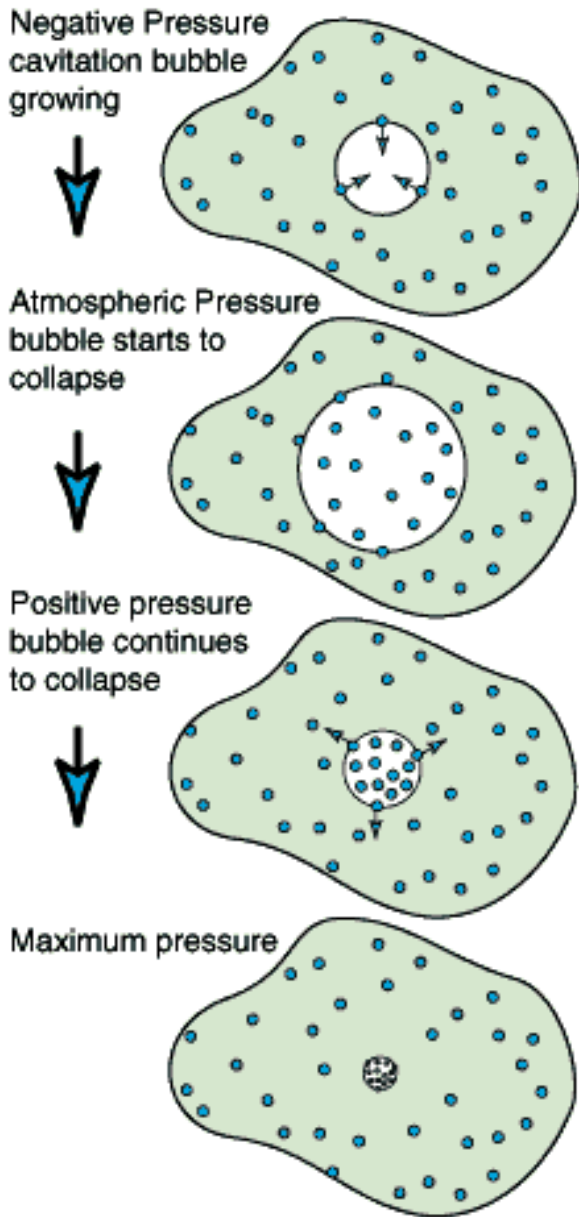

[◀ Prev Table of Contents Next ▶](#)



Ultrasonic Cleaning Fundamental Theory and Application

[◀ Prev Table of Contents Next ▶](#)

Maximizing Overall Cleaning Effect

Cleaning Chemical selection is extremely important to the overall success of the ultrasonic cleaning process. The selected chemical must be compatible with the base metal being cleaned and have the capability to remove the soils which are present. It must also cavitate well. Most cleaning chemicals can be used satisfactorily with ultrasonics. Some are formulated especially for use with ultrasonics. However, avoid the non-foaming formulations normally used in spray washing applications. Highly wetted formulations are preferred. Many of the new petroleum cleaners, as well as petroleum and terpene based semi-aqueous cleaners, are compatible with ultrasonics. Use of these formulations may require some special equipment considerations, including increased ultrasonic power, to be effective.

Temperature was mentioned earlier as being important to achieving maximum cavitation. The effectiveness of the cleaning chemical is also related to temperature. Although the cavitation effect is maximized in pure water at a temperature of approximately 160°F, optimum cleaning is often seen at higher or lower

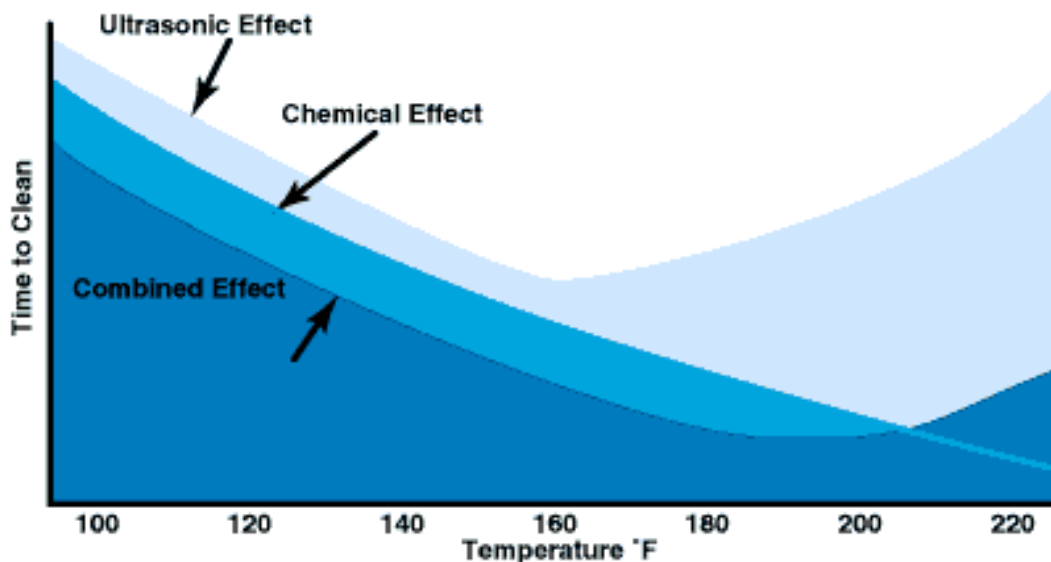

temperatures because of the effect that temperature has on the cleaning chemical. As a general rule, each chemical will perform best at its recommended process temperature regardless of the temperature effect on the ultrasonics. For example, although the maximum ultrasonic effect is achieved at 160°F, most highly caustic cleaners are used at a temperatures of 180°F to 190°F because the chemical effect is greatly enhanced by the added temperature. Other cleaners may be found to break down and lose their effectiveness if used at temperatures in excess of as low as 140°F. The best practice is to use a chemical at its maximum recommended temperature not exceeding 190°F



◀ [Prev Table of Contents Next](#) ▶



Ultrasonic Cleaning

Fundamental Theory and Application

◀ Prev Table of Contents Next ▶

Maximizing Overall Cleaning Effect *cont.*

Degassing of cleaning solutions is extremely important in achieving satisfactory cleaning results. Fresh solutions or solutions which have cooled must be degassed before proceeding with cleaning. Degassing is done after the chemical is added and is accomplished by operating the ultrasonic energy and raising the solution temperature. The time required for degassing varies considerably, based on tank capacity and solution temperature, and may range from several minutes for a small tank to an hour or more for a large tank. An unheated tank may require several hours to degas. Degassing is complete when small bubbles of gas cannot be seen rising to the surface of the liquid and a pattern of ripples can be seen.

The **Ultrasonic Power** delivered to the cleaning tank must be adequate to cavitate the entire volume of liquid with the workload in place. Watts per gallon is a unit of measure often used to measure the level of ultrasonic power in a cleaning tank. As tank volume is increased, the number of watts per gallon required to achieve the required performance is reduced. Cleaning parts that are very massive or that have a high ratio of surface

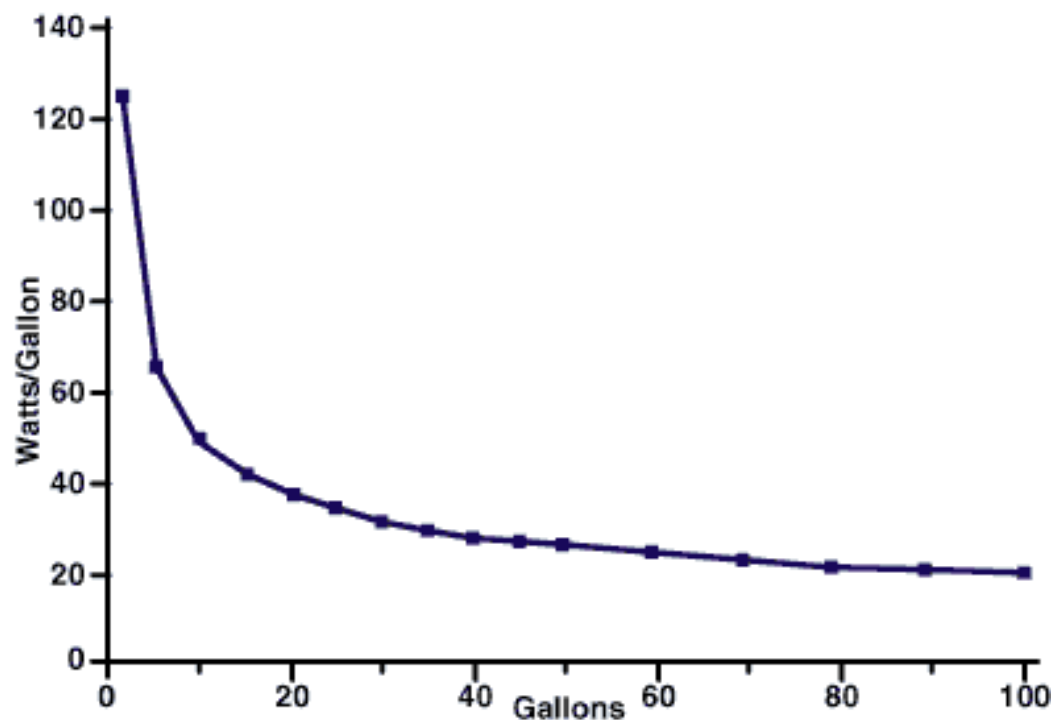

to mass may require additional ultrasonic power. Excessive power may cause cavitation erosion or "burning" on soft metal parts. If a wide variety of parts is to be cleaned in a single cleaning system, an ultrasonic power control is recommended to allow the power to be adjusted as required for various cleaning needs. Part Exposure to both the cleaning chemical and ultrasonic energy is important for effective cleaning. Care must be taken to ensure that all areas of the parts being cleaned are flooded with the cleaning liquid. Parts baskets and fixtures must be designed to allow penetration of ultrasonic energy and to position the parts to assure that they are exposed to the ultrasonic energy. It is often necessary to individually rack parts in a specific

orientation or rotate them during the cleaning process to thoroughly clean internal passages and blind holes.

Conclusion

Properly utilized, ultrasonic energy can contribute significantly to the speed and effectiveness of many immersion cleaning and rinsing processes. It is especially beneficial in increasing the effectiveness of today's preferred aqueous cleaning chemistries and, in fact, is necessary in many applications to achieve the desired level of cleanliness. With ultrasonics, aqueous chemistries can often give results surpassing those previously achieved using solvents. Ultrasonics is not a technology of the future -- it is very much a technology of today.



[◀](#) **Prev Table of Contents Next** [▶](#)