

## **MASTERSONIC: Single units from 100 W to 100 kW** **MMM, Universal and Wideband Multifrequency Power Supplies**

Multiple modulations operation: MMM technology  
 MMM, Universal Ultrasonic Power Supplies are replacing all other types of constant or sweeping frequency power supplies for driving all kind of piezoelectric transducers, submersible transducers, bench top cleaners, Sonochemical reactors... bringing number of advantages and new options.

The MASTERSONIC program represents a brand new approach in [Sonic and Ultrasonic Power Supplies](#). The **MASTERSONIC power supply equipment** is based on the **MMM Technology**, which enables producing high efficiency active power in wide-band sonic and ultrasonic vibrations, merging the state of the art of **DSP and Power Electronics**.



(OF)



(OW)



(IX)

**IP 65-68 & NEMA 4 Generator Housings also available**



Please visit our website for more details and have a look at our production line technology, or contact us directly with any inquiries.

# MMM Power Supplies Family

## OF, MMM Power Supplies



Technical characteristics	MSG.300.OF	MSG.600.OF	MSG.1200.OF
Main Supply Voltage	220/230 V; 50/60 Hz	220/230 V; 50/60 Hz	208 V to 240 V; 50/60 Hz (USA and EC)
Max. Input Power	400 W	700 W	1300 W
Non-modulated, carrier frequency range	19.020kHz ÷ 46.728 kHz	19.020kHz ÷ 46.728 kHz	19.020kHz ÷ 46.728 kHz (LF & HF models)
Modulated acoustic frequency range	Wideband, from Hz to MHz	Wideband, from Hz to MHz	Wideband, from Hz to MHz
Average Continuous Output Power	300 W	600 W	1200 W
Peak Output (max. pulsed power)	1500 W	3000 W	6000 W
Standard Options	<b>RS232/485, PLC, all other analog and digital controls All internal protections included</b>		
Output HF Voltage	~ 500 V-rms	~ 500 V-rms	~ 500 V-rms
Dimensions (h x w x d)	170x150x150mm	250x150x150mm	230 x 160 x 370
Weight	2 kg	3.6 kg	4 kg

MasterSonic open frame generator modules (OF series) are designed for internal mounting in the control cabinets of Ultrasonic Systems. Such cabinets should be very well ventilated, protecting the generator module from excessive dust, moisture, and harmful chemical agents. The installation and electrical connections of the generator should be performed by a qualified specialist in electronics who is experienced in Power Ultrasonics. MSG.X00.OF is designed as a component part for integration into Ultrasonic systems. Therefore it is not equipped with a Power Supply ON/OFF switch. Make sure the Ultrasonic System you are assembling is provided with such switch. Please read manuals for more information. **The most successful applications of OF generators are in Ultrasonic Cleaning.**

Please read manuals for more information (click the link below):

[http://mastersonic.com/documents/mmm\\_basics/mmm\\_power\\_supplies/msg-of-generators/](http://mastersonic.com/documents/mmm_basics/mmm_power_supplies/msg-of-generators/)

## OW, MMM Power Supplies



Technical characteristics	MSG.300.OW	MSG.600.OW	MSG.1200.OW
Main Supply Voltage	220/230 V; 50/60 Hz	220/230 V; 50/60 Hz	208 V to 240 V; 50/60 Hz (USA and EC)
Max. Input Power	400 W	700 W	1300 W
Non-modulated, carrier frequency range	21.435kHz ÷ 40.560 kHz	21.435kHz ÷ 40.560 kHz	21.435kHz ÷ 40.560 kHz (LF, MF & HF models)
Modulated acoustic frequency range	Wideband, from Hz to MHz	Wideband, from Hz to MHz	Wideband, from Hz to MHz
Average Continuous Output Power	300 W	600 W	1200 W
Peak Output (max. pulsed power)	1500 W	3000 W	6000 W
Standard Options	<b>RS232/485, PLC, all other analog and digital controls All internal protections included</b>		
Output HF Voltage	~ 500 V-rms	~ 500 V-rms	~ 500 V-rms
Dimensions (h x w x d)	170x150x150mm	250x150x150mm	230 x 160 x 370
Weight	2 kg	3.6 kg	4 kg

All MSG modular ultrasonic generators, MSG X00.OW, utilize the MMM Technology and are constructed with an open frame design intended for integration into Ultrasonic Systems providing appropriate housing and protection. OW series generators have much higher frequency resolution than OF series generators, making them convenient when precise frequency settings are important. **The MSG.X00.OW generators are intended mainly for application in ultrasonic materials processing.** MasterSonic generator modules (OW series) are designed for internal mounting in the control cabinets of Ultrasonic Systems. Such cabinets should be very well ventilated, protecting the generator module from excessive dust, moisture, and harmful chemical agents. The installation and electrical connections of the generator should be performed by a qualified specialist in electronics who is experienced in Power Ultrasonics. MSG.X00.OW is designed as a component part for integration into Ultrasonic systems. Therefore it is not equipped with a Power Supply ON/OFF switch. Make sure the Ultrasonic System you are assembling is provided with such switch. Please read manuals for more information. **Please read manuals for more information (click the link below):** [http://mastersonic.com/documents/mmm\\_basics/mmm\\_power\\_supplies/msg-ow-generators/](http://mastersonic.com/documents/mmm_basics/mmm_power_supplies/msg-ow-generators/)

## IX, MMM Power Supplies



Technical characteristics	<b>MSG.1200.IX</b>
Main Supply Voltage	208 V to 240 V; 50/60 Hz (USA and EC)
Max. Input Power	1300 W
Non-modulated, carrier frequency range	19.020kHz ÷ 46.728 kHz (LF, MF & HF models)
Modulated acoustic frequency range	Wideband, from Hz to MHz
Average Continuous Output Power	1200 W
Peak Output (max. pulsed power)	6000 W
Output HF Voltage	~ 500 V-rms
Dimensions (h x w x d)	250mm x 150mm x 450mm
Weight	10 kg

MSG modular ultrasonic generators (MSG XXX.IX) utilize the MMM Technology and are constructed with a separate housing as an independent power supply of piezoelectric acoustic loads. IX series generators have maximum of available options of MMM technology (practically all of the best options of OF and OW series generators, including many new options), and can be operated by people without background in High Power Ultrasonics. IX series power supplies are also very convenient for challenging R&D projects, laboratory applications and other scientific projects. IX generators are fully protected against overloading and load short-circuits.

Please read manuals for more information (click the link below):

[http://mastersonic.com/documents/mmm\\_basics/mmm\\_power\\_supplies/msg-ix-generators/](http://mastersonic.com/documents/mmm_basics/mmm_power_supplies/msg-ix-generators/)

## ACCESSORIES, INTERFACES, REMOTE, PLC AND PC CONTROLL TOOLS FOR ALL MMM GENERATORS



**Handheld Control Unit  
For manual control and settings**

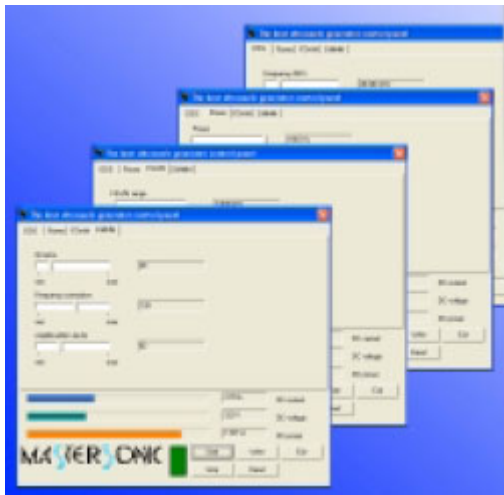

All MasterSonic, MMM generators can be controlled, being connected by RS485 link to a PC, using the software interface for enabling easy visual and multi-parameter control and settings.



**MMM-Link-2339 Adapter  
RS485 / RS232C+software**

**MMM-Link-2339\_16  
Option RS485  
Link extender16 generator**

**MMM-Link-2339\_64  
Option RS485  
Link extender16 generator**

**Interface cable**

### **STANDARD CARRIER FREQUENCY RANGES OF MMM GENERATORS**

Frequency range	OF	OW	IX
LF-range	17.5 kHz to 28.5 kHz	17.5 kHz to 28.5 kHz	17.5 kHz to 28.5 kHz
Resolution (Hz)	freq-step = 3-30 Hz	freq-step = 1 Hz	freq-step = 1 Hz
MF-range	19.020 kHz to 46.728 kHz	21.5 kHz to 40.5 kHz	19.02 kHz to 46.72 kHz
Resolution (HZ)	freq-step = 3-30 Hz	freq-step = 1 Hz	freq-step = 1 Hz
HF-range	24 kHz to 45 kHz	24 kHz to 45 kHz	24 kHz to 45 kHz
Resolution (Hz)	freq-step = 3 - 30 Hz	freq-step = 1 Hz	freq-step = 1 Hz

**Also available single Power Supply units until 100 kW**



**PS Cabinet**

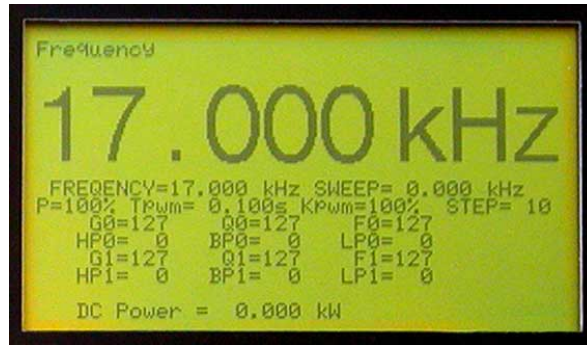

**PS Programming Interface and Display**

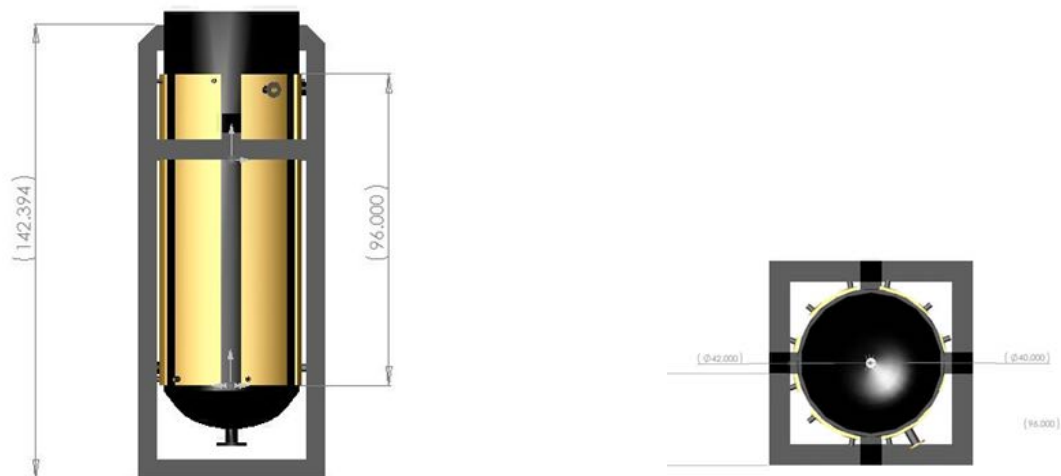

**15 kW acoustic load (Extractor: H = 3.6 m, OD = 1 m)**

# MMM SONIC & ULTRASONIC CLEANING & LIQUID PROCESSING

## MMM Technology: Multifrequency, Multimode, Modulated Sonic & Ultrasonic Technology

No other manufacturer has yet achieved and matched MMM exciting standards in precision cleaning. MMM is not only more efficient and effective than any other ultrasonic cleaning technology, it is UNIQUE.

- Seeing is the believing! Try the aluminum foil test for yourself! Place the foil sample into our ultrasonic bath and hold the foil for approx. 5 -10 seconds and you'll discover why there's simply no comparison with any other conventional ultrasonic cleaning machine.

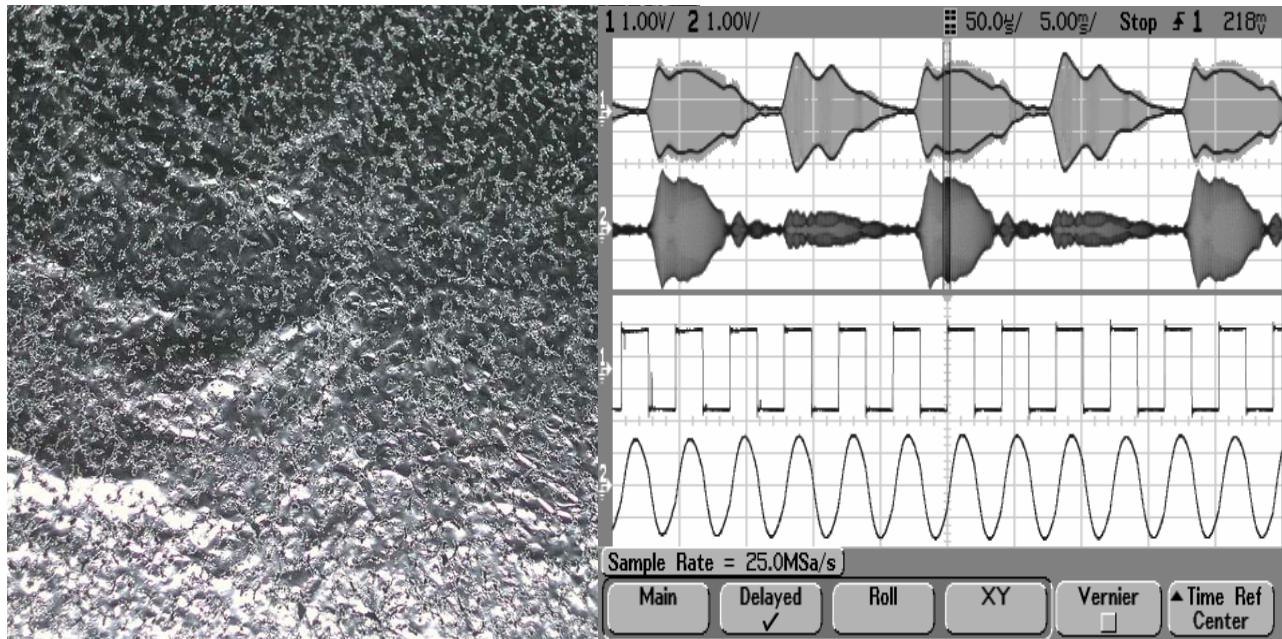

Left: Perfectly, uniformly perforated aluminum foil, after 5 to 10 seconds of exposure to MMM ultrasonic vibrations in an ultrasonic cleaner. Frequency Range: From Hz to MHz; From Infrasonic to Supersonic. Right: Load current and voltage shapes (modulated and carrier).

- Superior and deep penetration, independent of water levels.
- Reliability with extra power spread throughout the bath.
- Even distribution of ultrasonic energy throughout the liquid gives uniform and thorough cleaning of the surface without the risk of damage to fine parts and sensitive instrument.

- **Extremely efficient electronics and transducer coupling to ultrasonic bath (overall approx. 95% efficiency) eliminates or reduces the additional need for heating.**
- **Spatial distribution of ultrasonic activity inside of a cleaning liquid is homogenous (no dead zones, no standing waves, fast and large frequency sweeping, broadband spectrum, complex modulation).**
- **Cleaning solvents, detergents and additives can be significantly reduced, or even eliminated because of the very high cleaning activity of the acoustic broadband spectrum.**
- **Cleaning time can be several times shorter comparing to traditional ultrasonic cleaning technology.**
- **Fast liquid conditioning and degassing because of very large regulating zone between maximal and average ultrasonic power and because of the ability to switch instantaneously between acoustic spectrums.**
- **Smooth Ultrasonic, PWM-power regulation from 1% to 100%. Ultrasonic energy can be easily adjusted in order to clean very fine and sensitive parts**

- |  |  |
|--|--|
| <ul style="list-style-type: none"> <li>● Superior and deep penetration, independent of water levels.</li> <li>● Reliability with extra power spread throughout the bath.</li> <li>● No risk of damage to fine parts and sensitive instrument.</li> <li>● Extremely efficient electronics and transducer coupling to ultrasonic bath.</li> <li>● Homogenous spatial distribution of ultrasonic activity (no dead zones, no standing waves, fast and large frequency sweeping, broadband spectrum, complex modulation).</li> </ul> | <ul style="list-style-type: none"> <li>● Fast liquid conditioning and degassing. Smooth Ultrasonic, PWM-power regulation from 1% to 100%.</li> <li>● Fast and automatic ultrasonic-power and high-activity recovery.</li> <li>● Cavitation level control.</li> <li>● Wide bandwidth, programmable carrier frequency</li> <li>● Programmable frequency, phase and PWM modulation</li> <li>● Remote control, RS 485, RS 232C, handy keyboard, manual control...</li> </ul> |
|--|--|

- Overload protections: Over voltage, over current, thermal, short circuit
- Using the state-of-the-art MMM technology, "standing waves" do not exist and the efficiency goes well up!
- Applications: Sonochemistry, Cleaning, Sieving, Filtering, Metallurgy and Nanometallurgy, Catalysts and Free Radicals generation...

## *Benchtop ultrasonic cleaning systems*

### *MMM CLEANING & LIQUID PROCESSING TANKS*

**Wideband multifrequency systems for Liquid Processing, Cleaning and Sonochemistry: MMM technology (Operated with Mastersonic Power Supplies)**



- Constant output power independent of fluid level, temperature and load
- Specialized impulse and sweep mode drive powerful and uniform cavitation
- Wide range of tank capacities and accessories
- Electrical Source 110/120V, 220/240V
- Fabricated from cavitation resistant stainless steel 316L for inner tank, SS 304 for outer cover
- 20 micron hard chrome plated transducer plate
- Protected against dry running (without loading)
- Degas function
- Linear power control (0 to 100%)
- Accessories available: Tank cover, basket, drain valve
- Optional heater with analog or digital control
- Excellent for Sonochemistry, Cleaning, Nano-Powders Technologies, General Laboratory Applications...
- High density and uniform cavitation, no standing waves (From Hz to MHz)
- Since the cavitation occurs uniformly and omni directionally, sonic and ultrasonic energy distribution in the tank is very uniform, creating excellent cleaning and liquid processing effects
- Superior and fast cleaning effects compared to traditional systems
- Anti-corrosion (cavitation resistant, SUS314 and 316L & 20 microns hard Cr plating)
- MMM (multifrequency) concept prevents creation of standing waves, resulting that the surface-erosion damage is much lower than that of traditional tanks, operating on constant frequency.

## Specifications

Part number:	BCT-Y-40	BCT-Y-60	BCT-Y-80	BCT-Y-100	BCT-Y-120	BCT-Y-150	BCT-Y-240
INTERNAL DIMENSIONS (W)X(L)X(H)	200x380x250	280x380x300	300x380x410	380x410x460	330x530x510	430x530x510	580x530x560
	8"X15"X10"	11"X15"X12"	13"X15"X16"	15"X16"X18"	13"X21"X20"	17"X21"X20"	23"X21"X22"
OVERALL DIMENSIONS (W)X(L)X(H)	280x460x360	360x460x410	410x460x510	460x480x560	410x610x610	510x610x610	660x610x660
	11"X18"X14"	14"X18"X16"	16"X18"X20"	18"X19"X22"	16"X24"X24"	20"X24"X24"	26"X24"X26"
OUTPUT POWER (watt)	400	600	800	1000	1200	1500	2400
FLUID CAPACITY (liter)	19	32	51	70	89	117	174
HEATER	230V, 4A/1KW	230V, 5A/1KW	230V, 9A/2KW	230V, 13A/1KW	230V, 14A/1KW	230V, 18A/1KW	230V, 21A/1KW

(BCT = Benchtop Cleaning Tank)

## Accessories: Tank Cover, Basket, Drain Valve

### [Immersible box-type ultrasonic cleaning arrays](#)

Box type immersible ultrasonic cleaning transducers for high power ultrasonic systems including MMM multifrequency wideband sonic and ultrasonic technology.



### Types: MPI-ITB-28 and MPI-ITB-40

Submersible Ultrasonic Transducer follows traditional design configurations for submersible transducer systems.

- Welded case fabrication in a special stainless steel alloy extends operational life
- High grade PZT elements provide high ultrasonic cavitation
- Flexible stainless steel hose
- Available with base or side mount fixing
- Suitable for retro installation in existing cleaning tanks
- Produced in standard sizes or to special order dimensions
- The cleaning results are increased with the effective transducer arrangement
- Cr-plating increases total operating life and durability against cavitation.
- Uniform ultrasonic energy distribution and excellent cleaning effects
- Corrosion free and water proof design
- High quality transducer cases (SUS 306, SUS 316L)
- Strong transducers' bolt & adhesive type bonding
- Available frequencies: 28 KHz, 40 KHz, 68 KHz, 80 KHz, 120 KHz etc.
- General use cleaning and liquid processing transducers. Many models available
- MPI-ITB-28: Central operating frequency 28 kHz
- MPI-ITB-40: Central operating frequency 40 kHz
- Good for applications in MMM technology, and in constant frequency applications
- Continuous operating power: Different models from 300 W to 1500 Watts
- Best results will be achieved with Mastersonic, MMM power supplies.

## ***Application***

Used wherever sufficient space is available for the installation of submersible transducers.

## ***Construction***

The hermetically sealed, welded fabricated enclosure can be easily fitted to the base or side of a suitable tank using stainless brackets or hooks. The electrical connection is achieved by a flexible stainless steel hose. The free end of the hose should project above the liquid level and terminate in a clamp connector box. Screened high frequency cable is then used as the connection to the generator. The distance between the submersible transducer and the generator can be up to 30 m.

## ***Output Frequencies***

Submersible transducers working at 28 kHz are ideal for general purpose cleaning. The higher frequencies of 40, 80 and 120 kHz are more used for smaller or more sensitive items.

## ***Model sizes available***

[Contact](#) us to get more information about the special sizes made to suit customer specifications.

## Specification for ordering

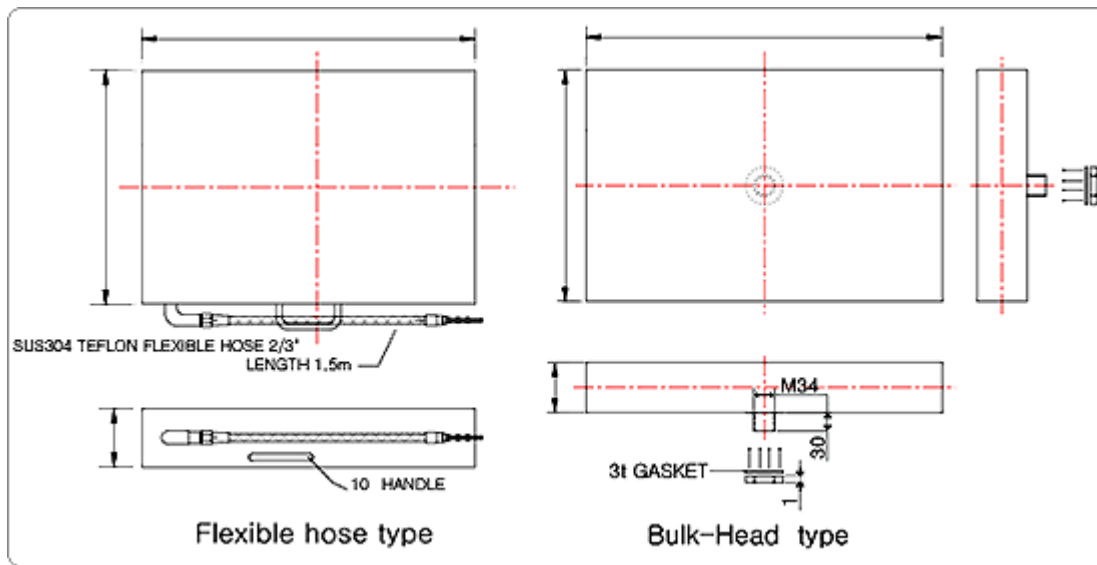

### Standard Integrated Plate Transducer Specifications (Other dimensions available on request)

<b>MODELS:</b>							
<b>MPI-ITB-28</b>	4010	6020	6021	1230	1231	1232	1233
<b>MPI-ITB-40</b>							
<b>POWER</b>	400 watt	600 watt		1200 watt			
<b>DIMENSIONS</b>	190x330	360x280	270x410	290x440	270x490	370x330	400x550
<b>ACTIVE AREA</b>	190x290	360x240	270x370	290x400	270x450	370x290	400x510
<b>MATERIAL</b>	SUS304, Hard-Cr plating (OPTION: SUS316L)						
<b>TRANSDUCERS</b>	8~9 pcs	12~14 pcs		24~28 pcs			

(ITB = Integrated Transducers Box)

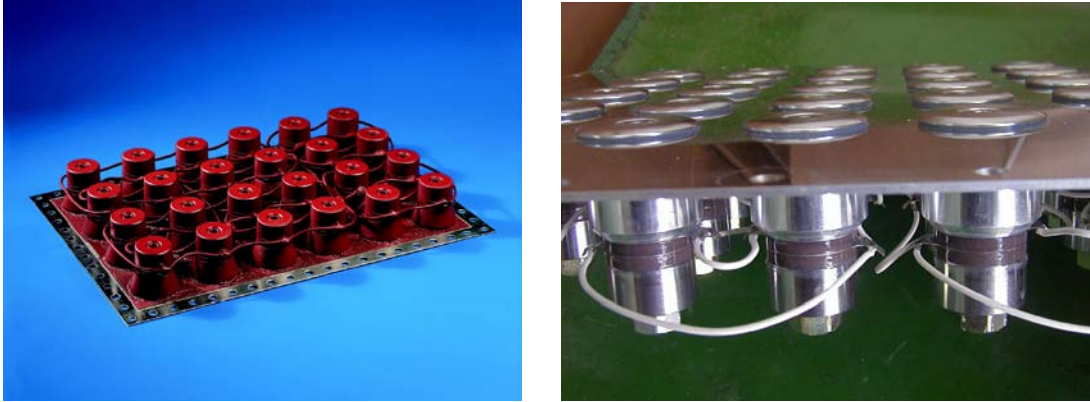

### Types: MPI-IPT-28 and MPI-IPT-40

Integrated Plate Ultrasonic transducers are generally used where space considerations restrict the installation of submersible transducers.

- Case fabrication in stainless steel alloy extends operational life
- High grade PZT elements provide high ultrasonic cavitation
- Can be supplied in different dimensions based on a repeat of 30 mm
- Available in 25, 40, 80 and 120 kHz
- General use cleaning and liquid processing transducers. Many models available
- MPI-IPT-28: Central operating frequency 28 kHz
- MPI-IPT-40: Central operating frequency 40 kHz
- Good for applications in MMM technology, and in constant frequency applications
- Continuous operating power: Different models from 300 W to 1500 Watts
- Best results will be achieved with Mastersonic, MMM power supplies

### ***Construction***

Integrated Plate transducers do not require space within the cleaning tank. The plates are mounted over an aperture cut in the tank wall and the radiating surface is in direct contact with the cleaning medium.

### ***Output***

Integrated Plate transducers are available to operate in the 28 kHz frequency band for general purpose cleaning and in the 40, 80 and 134 kHz band for smaller or more sensitive items.

### ***Models***

[Contact](#) us to get more information about the special sizes made to suit customer specifications.

## ***Inclusions***

Welded steel frame, sealing gasket, fixing screws.

MPI Model number:	IPT-4012	IPT-6020	IPT-6021	IPT-1231	IPT-1232
EFFECTIVE POWER	400W	600W		1200W	
ACTIVE AREA(BxF)	360x270	420x300	540x210	800x210	900x190
PLATE MATERIAL	SS-316L (option: HARD-Cr PLATING)				
TRANSDUCER ELEMENT	8-9PC	12-14PC		24-28PC	
ACCESSORY	M6x20 SS BOLT, WASHER, TEFLON PACKING				

(IPT = Integrated Plate Transducer)

## **MMM TUBULAR TRANSDUCERS: Wideband transducer arrays**



### **Types: MPI-ITT-28 and MPI-ITT-40**

- MMM Tubular Submersible Transducers are operated with Mastersonic Power Supplies.
- General use cleaning and liquid processing transducers.
- Good for applications in MMM technology, and in constant frequency applications
- Continuous operating power: Different models from 300 W to 1500 Watts
- Best results will be achieved with MMM generators
- Excellent for Sonochemistry, Cleaning, Waste Waters Processing, Filtering, Nano Powders Technologies, Catalysts and Free Radicals Creation...
- Original and unique design (patent pending),
- High density and uniform cavitation, no standing waves (From Hz to MHz)
- Since the cavitation occurs uniformly and omni directionally, all around the MMM tube, sonic and ultrasonic energy distribution in the tank is very uniform, creating excellent cleaning and liquid processing effects. Strong even cavitation along the entire tube length.
- Superior and fast cleaning effects
- Corrosion free, water proof design: This submersible transducer array is constructed of stainless steel with Hard-Cr plating (cavitation resistant, SUS304 and 316L & 20 microns hard Cr plating).
- MMM (multifrequency) concept prevents creation of standing waves, resulting that the surface-erosion damage is much lower than that of traditional transducers, operating on constant frequency.
- When driven by an MMM generator its unique construction and shape stimulate a full range of wideband harmonic frequencies and ultrasonic effects in liquid.
- The output power of MMM tubular transducers is not significantly affected by immersion depth, capacity of a bath or sonoreactor, load and liquid temperature variations, pressure...
- A tubular shape and number of available lengths makes it easy to install or place very simply in every available tank or reservoir. MMM tubular transducer is radiating omni-directionally on its integral external surface, without creating standing-waves inactivity.
- Compared to conventional submersible transducers MMM tubular transducers have several times longer operating life.
- Available in 600 W, 900 W, 1200 W, 1500 W, and higher on custom order.
- The Flexible Hose version allows the Tube Transducer to be submersed in any tank configuration, in any position (vertical, horizontal, diagonal), and may be easily moved from tank to tank.
- The Through Tank Wall version allows for secure and fixed mounting to a tank wall or base in any position (vertical, horizontal, diagonal).

- Many models available: MPI-ITT-28: Central operating frequency 28 kHz, MPI-ITT-40: Central operating frequency 40 kHz

### Specification for ordering

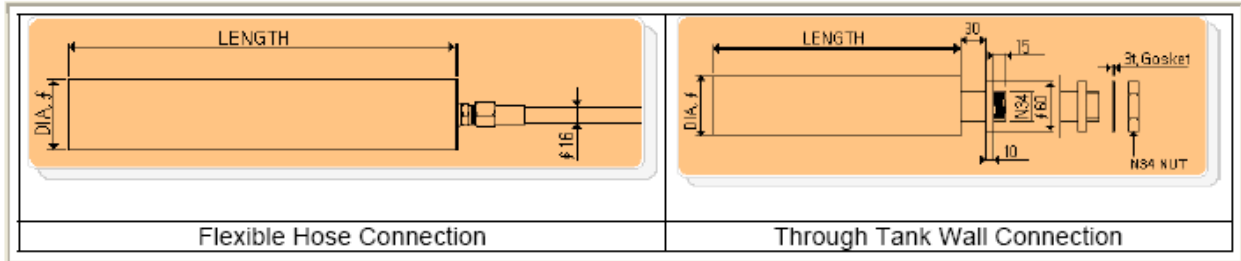

<b>MPI-MODEL</b>	<b>ITT-28-600</b>	<b>ITT-28-900</b>	<b>ITT-28-1200</b>	<b>ITT-28-1500</b>
<b>POWER</b>	600 watt	900 watt	1200 watt	1500 watt
<b>FREQUENCY</b>	28 KHz	28 KHz	28 KHz	28 KHz
<b>DIMENSION</b>	Ø 76.3 x L 310 mm	Ø 76.3 x L 460 mm	Ø 76.3 x L 580 mm	Ø 76.3 x L 680 mm
<b>MODEL</b>	<b>ITT-40-600</b>	<b>ITT-40-900</b>	<b>ITT-40-1200</b>	<b>ITT-40-1500</b>
<b>POWER</b>	600 watt	900 watt	1200 watt	1500 watt
<b>FREQUENCY</b>	40 KHz	40 KHz	40 KHz	40 KHz
<b>DIMENSION</b>	Ø 60.5 x L 310 mm	Ø 60.5 x L 460 mm	Ø 60.5 x L 580 mm	Ø 60.5 x L 680 mm

(ITT = Integrated Tubular Transducer)

### MMM Tube Transducer Possible Applications

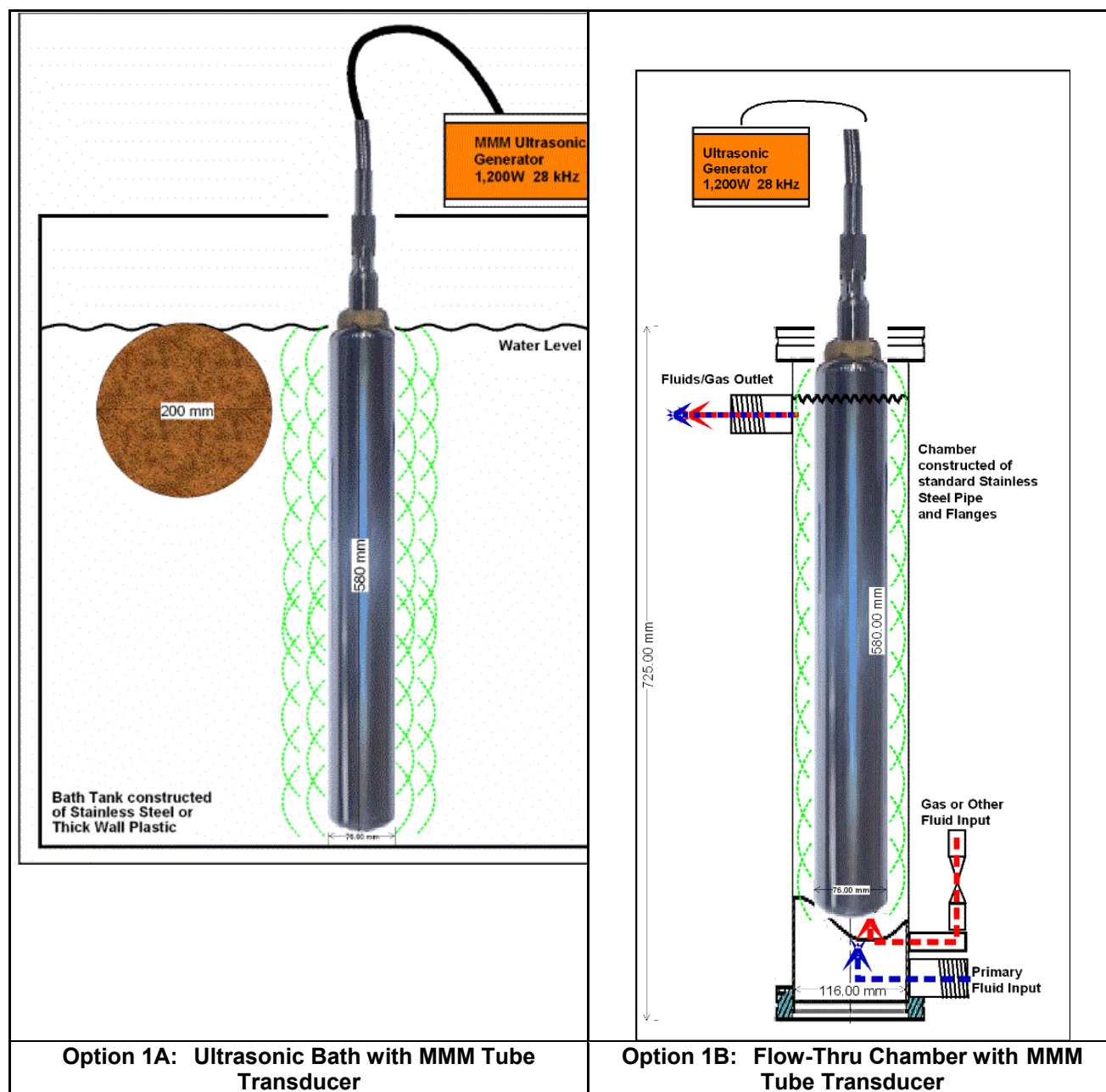

## Sonopush Mono Ultrasonic Transducer (Constant operating frequency)

The Sonopush Mono ultrasonic transducer is a major development in the generation of ultrasound.

- Solid titanium alloy radiator provides highest durability
- 360 degree radiating field provides omnidirectional energy and minimum dead-spot area
  - High efficiency – exceeds 95 %
- Particularly suitable for cleaning under vacuum or high pressure, sonoradiation of reagents and general Sonochemistry
- When used with Sonopower generators, Sonopush transducers are safe under dry-run conditions
  - Small footprint
    - Simple retrofit to existing tank systems
    - Available in 25, 30 and 40 kHz operating frequencies
- Ultrasonic Power Supplies for Sonopush Mono single-probe systems are well optimized to deliver very high ultrasonic energy into a liquid load, being fully protected against all accidental and over-loading situations.

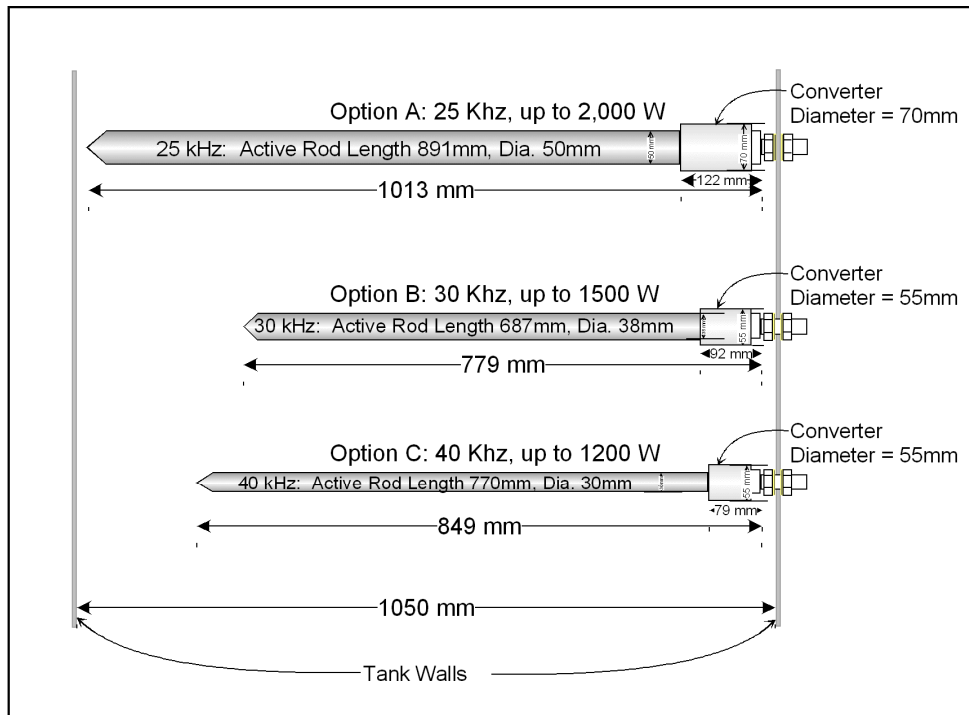

Picture of Converter Housing and Through Tank Wall Mounting Option. Standard length for external Stainless steel hose is 2.5 meters. Many options available.

## ***Applications***

A small footprint makes the Sonopush Mono transducer eminently suitable for retro-fitting to existing cleaning tank systems, even where these tanks were not designed for ultrasonic operation. Apart from use as in conversational cleaning systems, the Sonopush Mono can be used in vacuum, high pressure and Sonochemistry applications. The Sonopush Mono submersible transducers, used in conjunction with Sonopower generators, are totally dry-run-proof. Even fluid excess pressures up to 10 bar do not require extra protective measures to be taken.



## ***Effectiveness***

Sonopush Mono submersible transducers radiate energy in omnidirectional mode. Standing waves are thus less likely to develop and uniform activity within a volume of fluid is attainable at an efficiency better 95 %.

## ***Operational Safety***

Sonopush Mono transducers are machined from high quality titanium alloy. Improvements over other transducers and the use of a lower number of seals have resulted in better operational safety, longer life and a lower inadvertent damage risk.

### Sonopush Mono 25 kHz

Watt	kHz	Active Element Length A:	Total Length B:	Rod Diameter: Active/Non-Active
600	25 kHz	198 mm	320 mm	50/70
600	25 kHz	297 mm	419 mm	50/70
1000	25 kHz	297 mm	419 mm	50/70
1000	25 kHz	396 mm	518 mm	50/70
1000	25 kHz	495 mm	617 mm	50/70
1200	25 kHz	495 mm	617 mm	50/70
1500	25 kHz	495 mm	617 mm	50/70
1500	25 kHz	594 mm	716 mm	50/70
1500	25 kHz	693 mm	815 mm	50/70
2000	25 kHz	891 mm	1013 mm	50/70
2000	25 kHz	1089 mm	1211 mm	50/70
2000	25 kHz	1287 mm	1409 mm	50/70

### Sonopush Mono 30 kHz

600	30 kHz	270 mm	362 mm	38/55
600	30 kHz	354 mm	446 mm	38/55
1000	30 kHz	437 mm	529 mm	38/55
1000	30 kHz	520 mm	612 mm	38/55
1000	30 kHz	604 mm	696 mm	38/55
1200	30 kHz	604 mm	696 mm	38/55
1500	30 kHz	687 mm	779 mm	38/55

### Sonopush Mono 40 kHz

300	40 kHz	201 mm	280 mm	30/55
500	40 kHz	264 mm	343 mm	30/55
750	40 kHz	391 mm	470 mm	30/55
1000	40 kHz	517 mm	596 mm	30/55
1200	40 kHz	770 mm	849 mm	30/55

## **Sonopush Ultrasonic Transducer**

The Sonopush "Push-Pull" ultrasonic transducer is a major development in the generation of ultrasound - the modern transducer for demanding cleaning and Sonochemistry applications.

- Solid titanium alloy radiator provides highest durability
- 360 degree radiating field provides omnidirectional energy and minimum dead-spot area
- High efficiency – exceeds 95 %
- Particularly suitable for cleaning under vacuum or high pressure, sonoradiation of reagents and general Sonochemistry
- When used with Sonopower generators, Sonopush transducers are safe under dry-run conditions
- Small footprint
- Simple retrofit to existing tank systems
- Available in 25, 30 and 40 kHz operating frequencies
- Ultrasonic Power Supplies for Sonopush single-probe systems are well optimized to deliver very high ultrasonic energy into a liquid load, being fully protected against all accidental and over-loading situations.



## **Applications**

Apart from use as in conversational cleaning systems, the Sonopush can be used in vacuum, high pressure and Sonochemistry applications. The Sonopush transducers, used in conjunction with Sonopower generators, are totally dry-run-proof. For fully-immersible transducers see the [Sonopush Mono](#) range.

## **Effectiveness**

Sonopush Mono submersible transducers radiate energy in omnidirectional mode. Standing waves are thus less likely to develop and uniform activity within a volume of fluid is attainable at an efficiency better 95 %.

## **Operational Safety**

Sonopush transducers are machined from high quality titanium alloy. Improvements over other transducers have resulted in better operational safety, longer life and a lower inadvertent damage risk.

### Sonopush (Push-Pull) 25 kHz

Watt	kHz	Active Element Length A:	Total Length B:	Rod Diameter: Active/Non-Active
600	25 kHz	198 mm	438 mm	50/70
600	25 kHz	297 mm	537 mm	50/70
1000	25 kHz	297 mm	537 mm	50/70
1000	25 kHz	495 mm	735 mm	50/70
1200	25 kHz	396 mm	640 mm	50/70
1500	25 kHz	495 mm	735 mm	50/70
1500	25 kHz	693 mm	933 mm	50/70
1500	25 kHz	891 mm	1131 mm	50/70
2000	25 kHz	891 mm	1131 mm	50/70
2000	25 kHz	1089 mm	1329 mm	50/70
2000	25 kHz	1287 mm	1527 mm	50/70

### Sonopush (Push-Pull) 30 kHz

600	30 kHz	270 mm	456 mm	38/55
600	30 kHz	354 mm	540 mm	38/55
1000	30 kHz	437 mm	623 mm	38/55
1000	30 kHz	520 mm	706 mm	38/55
1200	30 kHz	604 mm	790 mm	38/55
1500	30 kHz	687 mm	873 mm	38/55

### Sonopush (Push-Pull) 40 kHz

300	40 kHz	201 mm	367 mm	30/55
500	40 kHz	264 mm	430 mm	30/55
750	40 kHz	391 mm	557 mm	30/55
1000	40 kHz	517 mm	683 mm	30/55
1200	40 kHz	770 mm	936 mm	30/55

## **SONICATORS**

In combination with our fixed frequency generators we offer a wide range of acoustic elements to meet all of your high power Sonicator / Homogenization needs. Using advanced digital generator technology we have set a new standard in high power liquid processing.

The new generator design offers new capabilities in tracking shifts in the center operating frequency. Normal generators are unable to manage even minor shifts (30 Hz to 100 Hz) when probes become de-tuned due to cavitation wear. Our systems can track simple probes over a very large frequency range of  $\pm 500$  Hz, a 1,000 Hz window in some cases. That means extended probe life, more reliable operation, and less maintenance.

Our converters feature a sealed front mass interface with upper air cooling ports for continuous operations. Boosters are available in titanium or aluminum, with or without mounting rings. Probes may be constructed to your specifications. Standard probes are made of high grade titanium in diameters up to 60 mm

### **Applications include:**

- Sonoreactors
- Homogenization
- Emulsification
- Dispersion of solids in liquid
- Disruption of bacterial cells, viruses and spores
- Acceleration of chemical and enzymatic reactions
- Liquids degassing
- Liquid Processing in static or flow cell chambers.
- Laboratory or industrial applications.

### **Key Features**

- Industries highest power delivery to the probe in liquids. Standard power supply options:
  - 300 watts
  - 600 watts
  - 1,200 watts
  - 2,000 watts
  - 3,000 watts
  - Higher power on special order
- Available in 20 kHz, 30 kHz, 35 kHz, 40 kHz, and custom frequencies on special order.
- Variable Probe Diameters:
  - 3mm (1/8") or smaller on special order
  - 6mm (1/4")
  - 13mm (1/2") (with or without replaceable tip)
  - 25mm (1")
  - 38mm (1 1/2")
  - 50mm (2")
  - Larger or any custom size on special order

- Half or Full Wave Probes
- Boosters in Standard Gain (0.4, 0.5, 0.6, 1.0, 1.25, 1.5, 1.75, 2.0, 2.5) or custom ratios on special order.

## **High Power Piston Probe SONICATOR**

- **20 kHz Fixed frequency**
- **2,000 watts max**
- **Booster Ratio 1:2.0**
- **Full-wave Probe (titanium)**
  - **Diameter = 50mm**
  - **Length = 250 mm**
- **Very high axial energy produces strong cavitation and acoustic power for mixing, homogenization, flock & particle breakdown.**
- **New probe design also provides high radial energy for strong cavitation along the probe length.**
- **Ultrasonic Power Supplies for above-described single-probe systems are well optimized to deliver very high ultrasonic energy into a liquid load, being fully protected against all accidental and over-loading situations.**

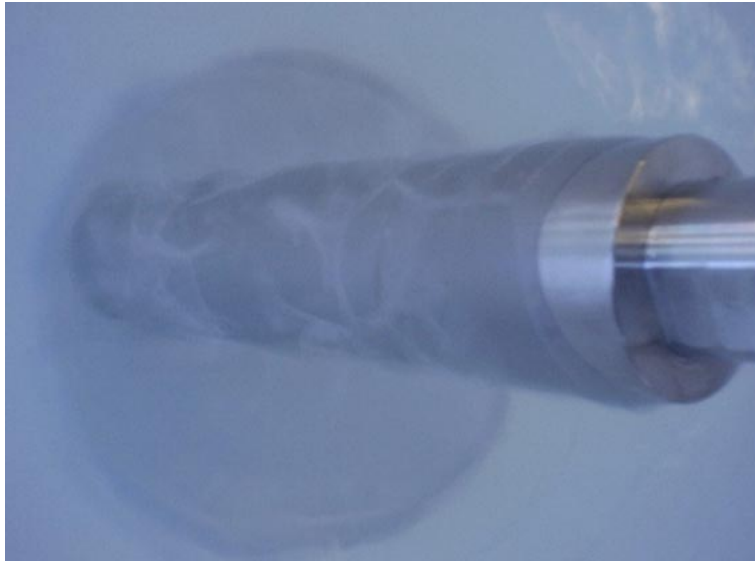

Power Draw Test: In Water		
Probe Submerged	50% Amplitude	100% Amplitude
Full submerge:	1,000 W	1,500 W
½ Submerge:	600 W	1,000 W
½ Submerge:	600 W	1,000 W
¼ Submerge:	300 W	600 W

**What to order (minimal configuration): Converter, Booster, Probe, and Power Supply**

## COMPONENTS AND PARTS FOR HIGH POWER ULTRASONICS

[Ultrasonic cleaning transducers for use with conventional and wideband ultrasonic cleaning baths](#)

### Different Cleaning Transducers

Ultrasonic cleaning transducers for high power ultrasonic systems including MMM multifrequency wideband sonic and ultrasonic technology.



### Ultrasonic transducers (IBLT types)

- Highest mechanical quality factor (highest efficiency and minimal heat dissipation)
- Very low series resonance impedance (lower driving voltage), and very high parallel resonance impedance (low losses)
- Stable and durable under severe working environment and elevated temperature
- Made of high grade stainless steel, highest quality aluminum and high density PZT

Here are two of the most widely used, excellent qualities cleaning transducers (already sold in millions of pieces): 28 kHz and 40 kHz, 50 Watts:

### 28 kHz, cleaning transducers: MPI-C-28



Total axial length = 80 mm,  
 Front mass diameter = 45 mm, h = 39 mm  
 Back mass diameter = 35.5 mm, h = 19 mm  
 Central operating frequency: 28 kHz  
 Piezoceramic ring: OD = 35 mm, t = 5mm  
 Continuous operating power: 50 Watts  
 Best results will be achieved with MMM power supplies  
 Good for applications in MMM technology, and in constant frequency applications  
 MPI-C-28 is the general use cleaning and liquid processing transducer

### 40 kHz, cleaning transducers: MPI-C-40



Total axial length = 48 mm,  
 Front mass diameter = 50 mm, h = 19 mm  
 Back mass diameter = 38.5 mm, h = 14 mm  
 Central operating frequency: 40 kHz  
 Piezoceramic ring: OD = 38 mm, t = 5 mm  
 Continuous operating power: 50 Watts  
 Best results will be achieved with MMM power supplies  
 Good for applications in MMM technology, and in constant frequency applications  
 MPI-C-40 is the general use cleaning and liquid processing transducer

**Wideband, cleaning transducers:**  
**MPI-C-4090M & MPI-C-2575M**

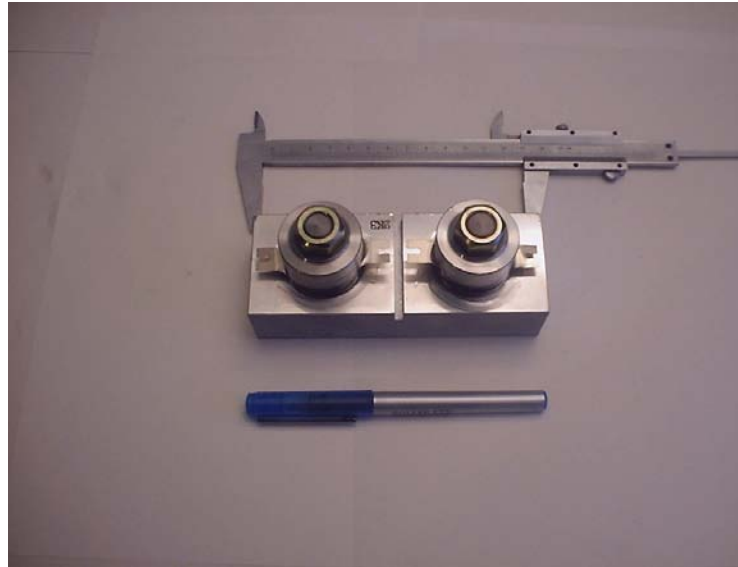

MPI-C-4090M & MPI-C-2575M, general use cleaning and liquid processing transducers

Good for applications in MMM technology, and in constant frequency applications

MPI-C-4090M, operating frequency range without MMM: 40 to 90 kHz

MPI-C-2575M, operating frequency range without MMM: 25 to 75 kHz

Continuous operating power (water loaded): 100 Watts

Best results will be achieved with MMM power supplies

## MPI WELDING & HIGH POWER CONVERTERS

### 20 & 40 kHz welding Converters (MPI-3520-6PS and MPI-3540-2PS)

-MPI-3520-6PS, 20 kHz, 1500 W  
 -Total Length = 109 mm,  
 -Piezoceramics OD = 35 mm, t = 5 mm  
 -Piezoceramic thickness, t = 5mm  
 -Aluminum-mass output diameter = 25.5 mm,  
 h = 56 mm  
 -Steel back mass diameter = 35.5 mm, h =  
 20.5 mm  
 -Largest middle diameter = 45 mm  
 -Threaded hole in aluminum mass = 3/8-24  
 UNF  
 f-r = f-s = 20.7 kHz (3.7  $\Omega$ )  
 f-p = f-a = 23.42 kHz (170 k $\Omega$ )

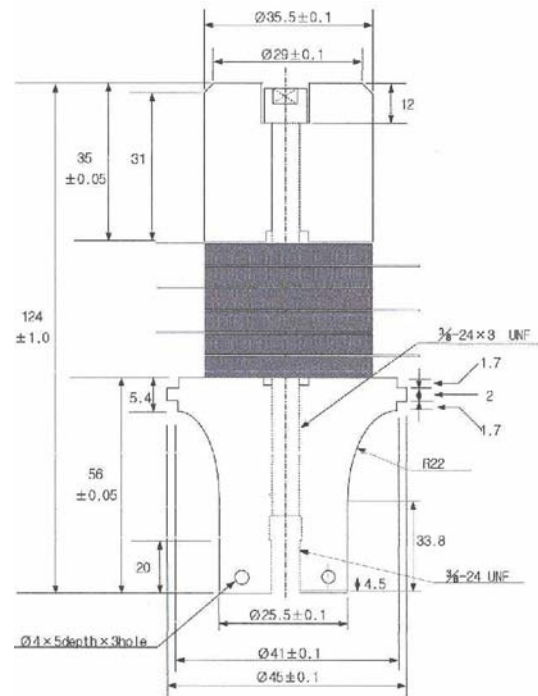

-MPI-3540-2PS, 40 kHz, 500 W  
 -Total Length = 62 mm,  
 -Piezoceramics OD = 35 mm, t = 5 mm  
 -Piezoceramic thickness, t = 5mm  
 -Aluminum-mass output diameter = 25.5 mm, h = 31  
 mm  
 -Steel back mass diameter = 35.5 mm, h = 20.5 mm  
 -Largest middle diameter = 39 mm  
 -Threaded hole in aluminum mass = M8  
 f-r = f-s = 38.05 kHz (6  $\Omega$ )  
 f-p = f-a = 41.27 kHz (290 k $\Omega$ .)

**For larger orders certain non-essential dimensions can be modified**  
**All converters are silicone surface-coated**  
**Front aluminum mass: AL7075, Ultrasonics Grade**  
**Back mass: Stainless Steel 304**

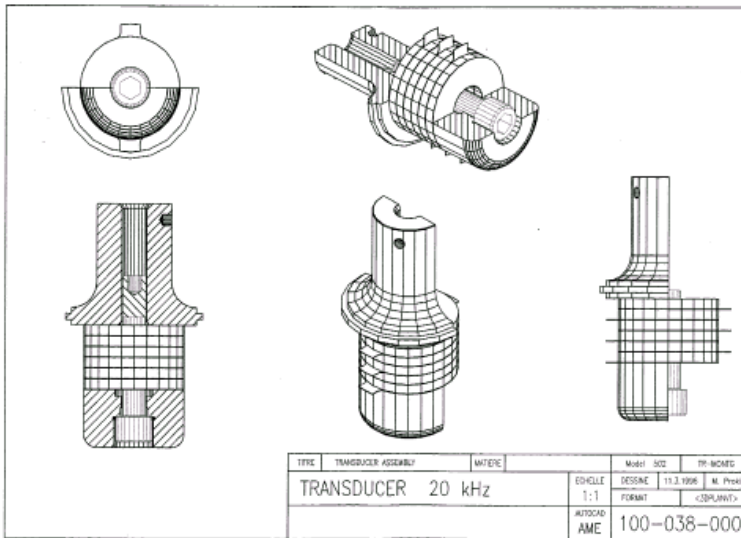

**MPI-5020-6PS, 20 kHz, 3 kW, Without Housing**  
Optimized 502/932R, Branson Converter

**BRANSON 502/932R, Typical Model Parameters Variations**

	In Series Resonance	In Parallel Resonance
<b>Model Parameters for Non-Loaded Converter</b> <b>(Measured on the random, standard-production-quality sample &gt; 100 pcs. of converters, taken after assembling)</b>	$C_{op} \in [15.3 - 18.1] \text{ nF}, \pm 3\%$	$C_{os} \in [18.7 - 22.05] \text{ nF}, \pm 3\%$
	$C_1 \in [3.92 - 4.05] \text{ nF},$	$C_2 \in [79 - 101.53] \text{ nF},$
	$L_1 \in [17.53 - 18.7] \text{ mH}$	$L_2 \in [570.50 - 747] \mu\text{H},$
	$R_1 \in [1.75 - 4.6] \Omega, \pm 20\%$	$R_2 \in [94 - 250] \text{ K}\Omega, \pm 20\%$
	$f_1 \in [18435 - 18905] \text{ Hz}, \pm 0.5\%$	$f_2 \in [20635 - 20912] \text{ Hz}, \pm 0.5\%$
	$Q_{m01} \in \langle Q_{m01} \rangle \pm 20\%$	$Q_{m02} = \langle Q_{m02} \rangle \pm 20\%$



**Protected Flex-Housing: MPI-5020S-6PS**

**IP 65 & NEMA 4 compliant** (both Converter and Connector)  
Good for single frequency and broad band operating regimes (MMM)  
Large mounting area, Flex-housing, Watertight, Shock-resistant

**CHARACTERISTICS:**

**-MPI-5020-6PS and MPI-5020s-6PS, 20 kHz, 3000 W**

-Total Length = 117 mm,

-Piezoceramics OD = 50 mm,

-Piezoceramic thickness,  $t = 5\text{ mm}$

-Aluminum-mass output diameter = 38 mm,  $h = 61\text{ mm}$

-Largest middle diameter (AL mass) = 69 mm

-Steel back mass diameter = 51 mm,  $h = 23.5\text{ mm}$

-Threaded hole in aluminum mass =  $\frac{1}{2}$ ", UNF20

$f-r = f-s = 18.76\text{ kHz}$  ( $2.6\ \Omega$ )

$f-p = f-a = 20.77\text{ kHz}$  ( $90\text{ k}\Omega$ )

Fully compatible with 502 Branson models, 20 kHz, 3 kW

**All converters are silicone surface-coated**







**Front aluminum mass: AL7075, Ultrasonics Grade**

**Back mass: Stainless Steel 304**

**In MMM applications applicable for carrier frequencies from 10 kHz to 30 kHz**

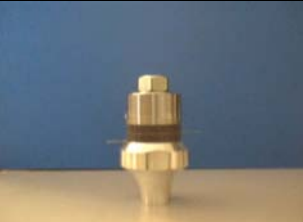
**Applications: Extruders, Wires & Tubes Drawing, Atomizers, Liquid Alloys Treatment, Defoaming, Mixers, Sonochemical Reactors, Waste Waters Processing, Supercritical, Liquid CO-2 Reactors, Extractions, MMM Cutting, Degassing, Clamp-On Systems...**

# High Power Converters Gallery

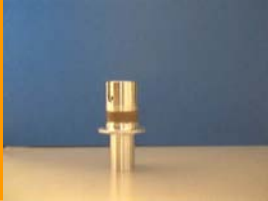
		<p>Water-jacket cooled also available (for very high operating temperatures and heavy loading)</p>			
<p>5020-6PS 20 kHz, 3000 W</p>	<p>5020S-6PS 20 kHz, 3000 W Silicone flex housing</p>	<p>5020S-6PS-WC 20 kHz, 3000 W Silicone flex housing &amp; water jacket</p>			
		<table border="1"> <tr><td>No housing</td></tr> <tr><td>Silicone flex housing</td></tr> <tr><td>Water-jacket cooled</td></tr> </table>	No housing	Silicone flex housing	Water-jacket cooled
No housing					
Silicone flex housing					
Water-jacket cooled					
<p>20 kHz, 1000 W 3520-6PS 3520S-6PS 3520S-6PS-WC</p>	<p>20 kHz, 500 W 2520-4PSF 2520S-6PS 2520-4PSF-WC</p>				
					
<p>36 kHz, 500 W</p>	<p>36 kHz, 500 W Metal-ring protected</p>	<p>36 kHz, 500 W Shrinkable-Teflon tube protected</p>			
<p>Silicone flex housing models also available</p>					
		<p>Silicone flex housings also available</p>			
<p>3540-2PS 38 kHz, 500 W</p>	<p>2536-2PSF 36.8 kHz, 500 W</p>				

## Different Welding Transducers

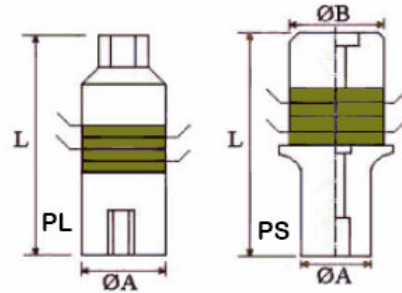

### Specification for ordering

CONVERTER TYPE	RESONANT FREQUENCY	RESONANT IMPEDANCE	STATIC CAPACITANCE	RADIATING SURFACE DIAMETER	TOTAL LENGTH	MAX OPERATING POWER
	kHz	Max $\Omega$	pF	TAP	mm	watt
5020-4PL	19.8 +/-0.3	10	13000 +/-15%	M18, P1.5	125.3	1,400
5020-4PS	19.6 +/-0.3	10	13000 +/-15%	M18, P1.5	114.3	1,500
6015-4PL	14.8 +/-0.2	10	12000 +/-15%	M20, P1.5	161.8	1,800
6015-4PS	14.7 +/-0.2	10	12000 +/-15%	U.N.F	148.3	2,200
70150-4PL	14.8 +/-0.2	8	17000 +/-15%	M24, P1.5	163.6	2,400
3020-2PL	19 +/-1	100	2500 +/-10%	M10, P1.0	131.2	300
3020-2PLF	19 +/-1	100	2500 +/-10%	M10, P1.0	131.2	300
3028-2PL	28 +/-1	30	2500 +/-10%	M10, P1.0	91.5	200
3028-2PS	28 +/-1	30	2500 +/-10%	M8, P1.25	95.4	200
3028-2PLF	28 +/-1	30	2500 +/-10%	M10, P1.0	93	200
4427-4TPL	27 +/-1	20	7600 +/-10%	M12, P1.0	107	400
3540-2PS	38 +/-1	20	3800 +/-10%	M8, P1.0	61.5	200
3550-2PL	50 +/-1	50	2300 +/-10%	M10, P1.0	48	200
1560-2PL	60 +/-2	100	500 +/-15%	-	84	100
2030-4TPL	27 +/-1	60	3400 +/-10%	M6, P1.0	86.3	300