

SUBMICRON CLEANING WITH HIGH FREQUENCY CERAMIC TRANSDUCERS

An In Depth Look at the Advantages of CREST ULTRASONICS'
Patented Ceramically Enhanced Transducer Technology

By J. Michael Goodson

Which Should You Choose, A or B?

CHART A

Crest Ceramic 132 kHz

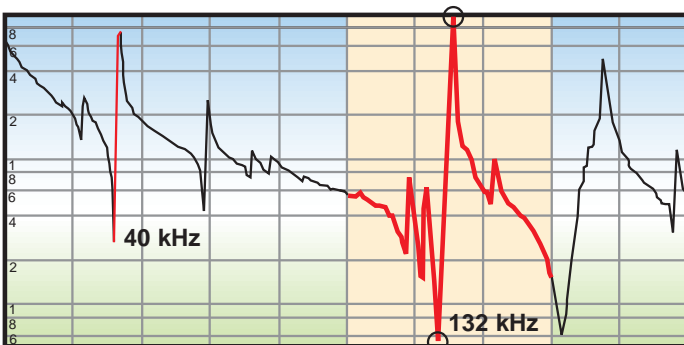

Use a ceramic ultrasonic frequency where the transducer is designed to capture direct third harmonic frequencies.

CHART B

Competitor's 40, 72, 104 and 170 kHz

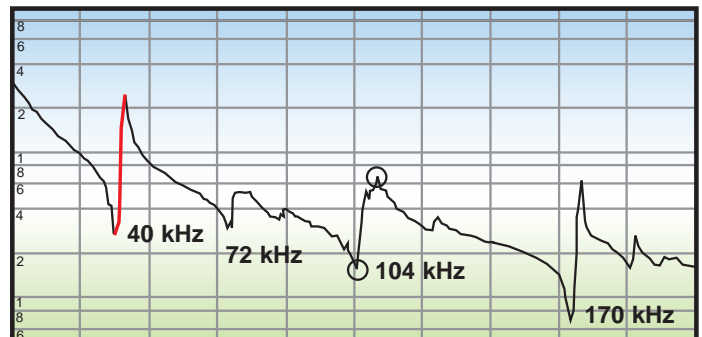

Use a metal stacked first harmonic frequency (40 kHz) and pick up third subharmonics at the reduced subharmonic strength.

The superiority of chart A over chart B is clearly evident. High-tech ceramics make possible the direct stacking of high frequencies that before were only available as subharmonics of metal stacked frequencies (which derive their primary power from the weaker first harmonics). The stacking of a ceramic transducer to the exact frequency results in a significantly increased level of activity.

Please also note that even with a third harmonic direct stacking, the Crest first harmonic (40 kHz) is stronger than the competitor's metal stacked 40 kHz.

CERAMICS TRANSMIT SOUND BETTER

The acoustical speed at which sound travels through high-tech ceramics is 63% to 125% greater than aluminum, stainless steel or titanium:

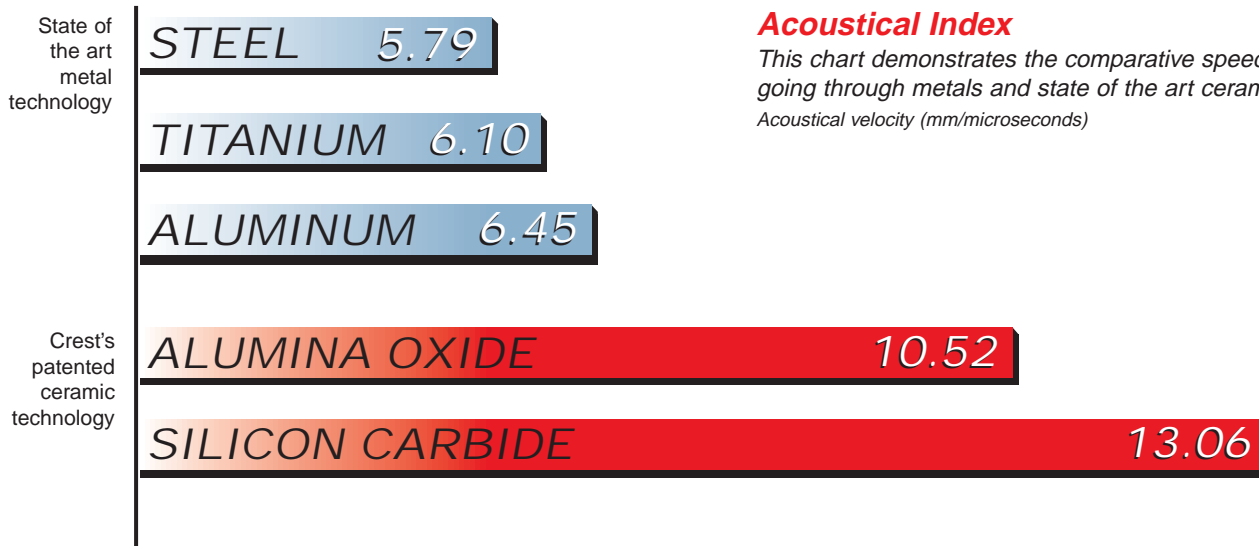

The problem with traditional metal stacked transducers is that solid metal is actually made up of strands and strands of metal, which under high magnification is actually quite porous. In the transmission of sound waves, the porosity becomes very significant.

High-tech ceramics like alumina oxide and silicon carbide have a composition of molecules so minute, the porosity is near zero. Their surfaces are so flat they can be measured in 1,000,000 of an inch. As a result they offer superior acoustical speed and an improved surface interface. Thus stacking an ultrasonic transducer with ceramics greatly enhances the transmission of ultrasonic energy. The near perfect transmission of sound also reduces the amount of stress involved with transmitting ultrasonic energy, resulting in increased day-to-day reliability and a much longer trouble-free life for the system in use.

HOW STACKING WITH CERAMICS WORKS

Taking into consideration the acoustic superiority, transmitting sound into the ceramic resonator directly before the aluminum head mass results in more sound waves being transferred and with greater intensity.

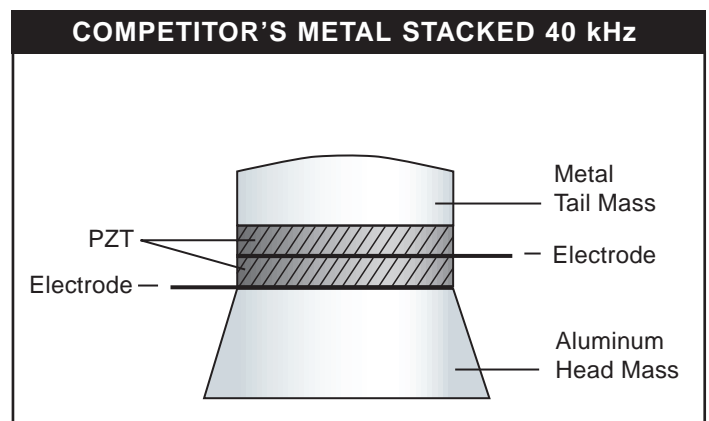
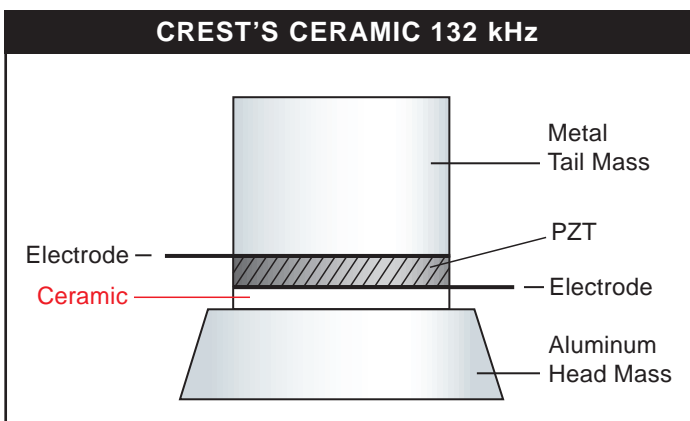

(Continued)

The ceramic interface allows for the near perfect transmission of sound.

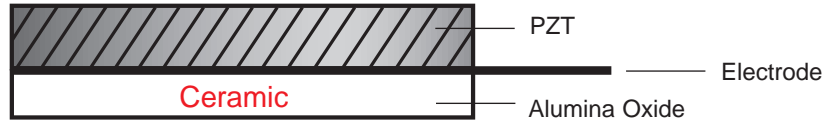

Silicon Carbide can further enhance the transmission of sound in some situations.

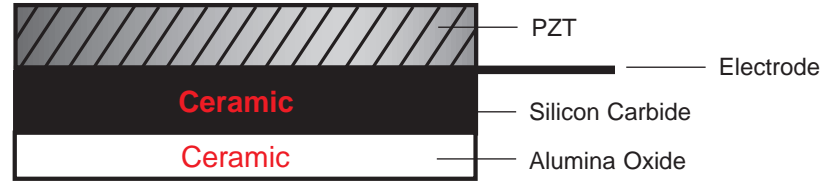

THIRD HARMONIC FREQUENCIES... THE BIGGEST ADVANTAGE

What is a Third Harmonic Frequency?

Piezo Ceramic Crystals (PZTs) used for creating ultrasonic energy are known by their first frequencies, the traditional Crest 40 kHz PZT for example (see chart 1). Expand the chart and you see an even stronger third harmonic frequency (chart 2). Looking at the chart's full spectrum, you will see a number of different harmonics (see chart 3).

The harmonics are based on the number of signals that can be readily identified with some subjective expectations of strength which makes them useful. High-tech ceramics make possible the direct stacking of high frequencies that were previously only available as sub-harmonics of metal stacked frequencies (which derive their primary power from first harmonics). Third harmonics are always stronger than first harmonics. Therefore the direct stacking of third harmonics is highly desirable. Fifth and higher harmonics also offer good potential for future development.

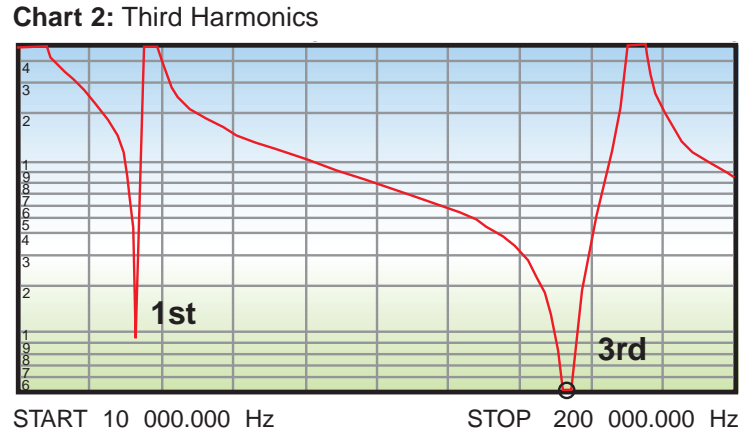
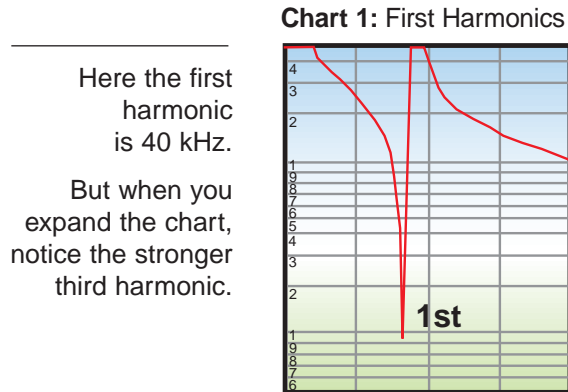

If you do a complete scan of the 40 kHz PZT you can see a total of six (6) strong harmonics, with 40 kHz (the first harmonic) being the weakest. The advantage of being able to directly stack harmonics other than the first gives the user of ceramic stacked transducers a big advantage. Metal stacking works off the weakest harmonics.

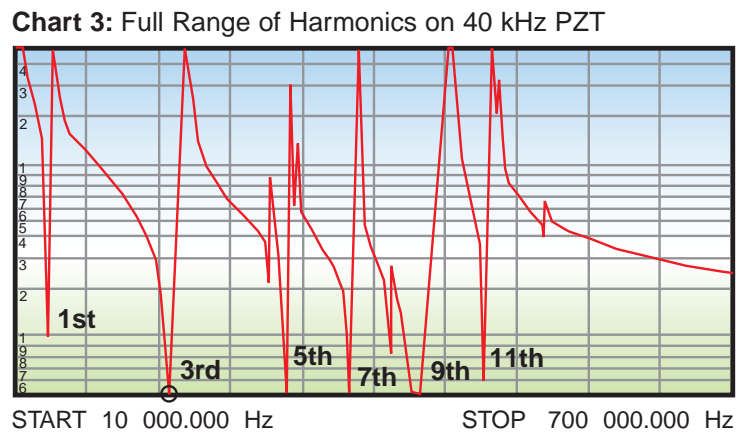

(Continued)

HOW MANY THIRD HARMONIC POSSIBILITIES ARE THERE FOR HIGH FREQUENCIES?

Is it possible to create a third harmonic frequency at any point between 100 and 350 kHz?

Yes, you can create third harmonics up to 500 kHz but it would be cost prohibitive for the end user, as you go above the 325 to 350 kHz range.

Creating Third Harmonics: The determining factors in creating third harmonics are the outer and inner dimensions of the PZT crystal.

IS THE CERAMIC 132 kHz THE UNIVERSAL TRANSDUCER OF THE FUTURE?

No. It is a great third harmonic frequency, but with ceramic stacking you have the luxury of having a family of third and higher harmonics designed to meet specific needs.

THE CERAMIC 200 kHz

This new introduction will challenge the megasonic frequencies and their modest intensity. Like other third harmonics, it is extremely intense for such a high frequency. With the ceramic intensity, it is likely to replace many of the megasonic units on the market.

Reliability: Using the Martin Walter power supply we expect the transducers to last for several years compared to most megasonic transducers' life expectancy of 6 to 12 months.

Crest Ceramic 200 kHz



HOW RELIABLE ARE THIRD HARMONIC CERAMIC TRANSDUCERS?

After more than 18 months since its introduction, and with more than 75 ceramic 132 kHz systems installed world wide, not one single generator/transducer installation failure has been reported anywhere in the world.

It seems unbelievable, but it is true. This reliability can be directly attributed to the enhanced efficiency of transmitting ultrasonic sound waves using high-tech ceramics and state-of-the-art Martin Walter AG power supplies to power the transducers.

HOW GOOD ARE THE CLEANING RESULTS?

- A disk media manufacturing facility cut its process time in half and got the cleanest disks ever.
- Another disk media manufacturing facility improved its yield by 4%. The equipment pays for itself in 79 days.
- A slider fab application increased yield to 100%.
- A military application using solvent improved process time by 40%.
- An Asian solvent/alcohol application for cleaning & drying produced the highest HSA yield ever recorded, with submicron specifications.
- HSA/HGA yields in disk drive applications are at new highs.
- PCB board cleaning is seeing the best results ever.

The ultimate test of a new technology is its acceptance in the marketplace. Ceramically enhanced third and higher harmonic transducers are meeting the test and winning in the **United States, Japan, Singapore, Philippines, Malaysia, Thailand, South Korea, Taiwan, China, The United Kingdom and Europe**. All these countries have successful third harmonic-powered ultrasonic cleaning system installations from Crest.

CREST ULTRASONICS CORPORATION

P.O. Box 7266 • Scotch Road • Trenton, NJ 08628 • Phone (609) 883-4000 • Fax (609) 883-6452

www.crest-ultrasonics.com

Toll Free: 1 800-99 CREST (1-800-992-7378)