

Multifrequency Powders Sieving, Screening and Powders Related Applications

Main Web Site: <http://www.mpi-ultrasonics.com>

Download Server: <http://mastersonic.com>

Email: mpi@bluewin.ch

MPI *Interconsulting*

ULTRASONICS - SONOCHEMISTRY - INNOVATION

Location:

Neuchâtel, Le Locle, Switzerland

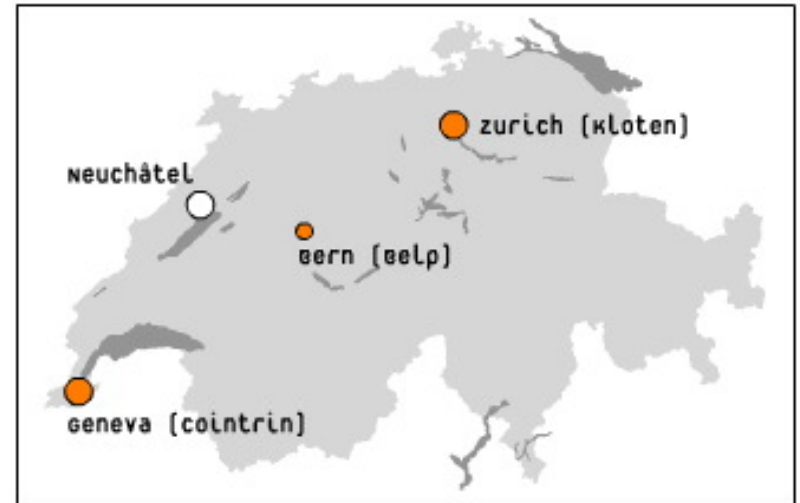
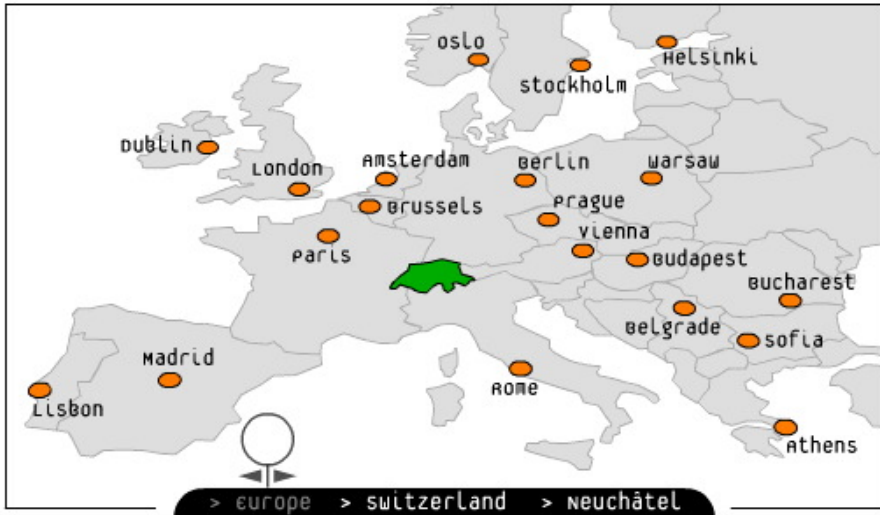



MMM Sieving Technology Basics

- ❑ Multi-Frequency Multimode, Modulated Sonic & Ultrasonic Technology (MMM Power Supplies).
- ❑ A totally new approach in the world of acoustic technologies.
- ❑ Unlike Fixed-Frequency systems we adapt through advanced Digital Signal Processing (DSP) of feedback waveform and new modulation techniques producing wide frequency band acoustic field. Any sieving screen can be agitated using MMM Power Supplies.

MMM Technology Advantages

- ❑ Sonic and ultrasonic parameters in MMM Power Supplies are fully programmable and controllable to offer high operating efficiency and effectiveness for any complex mechanical system, consisting of arbitrary resonating elements.
- ❑ MMM creates powerful 3D sonic and ultrasonic activity in liquids and solids with arbitrary shapes and sizes.
- ❑ MMM Sonic & Ultrasonic Vibrations are covering and sweeping an extremely wide frequency band to create uniform and homogenous distribution of acoustical activity inside of the vibrating medium.
- ❑ Standing waves are eliminated and the whole medium is fully agitated.
- ❑ Adapt to any kind of transducer, any number or any power.



MMM Sieving & Screening Resume

- We offer generator and transducer components for systems integrators and OEMs to make Ultrasonic Sieving and Screening systems. We offer our clients the freedom to construct and supply their own screen resonator rings or cassettes.
- **Fixed Frequency Systems:**
- When matched with our Fixed-Frequency generators the ring resonators must be tuned to operate at the system resonant frequency.
- **Multi-Frequency Systems:** MPI now offers the industry's most advanced ultrasonic technology for sieving and screening applications. When properly adjusted our patented MMM (Multifrequency, Multimode, Modulated) ultrasonic generators can stimulate highly efficient wideband (sonic to megahertz) acoustic energy to nearly any sieve or screen shape. Key benefits to the MMM ultrasonic technology are:
 - Wideband (sonic to megahertz) acoustic energy provides greater sieve/screen stimulation to improve process volumes (kg/hr) beyond the limitations of standard fixed frequency systems.
 - MMM eliminates the standing waves seen in fixed frequency systems.
 - Eliminates binding in low amplitude nodal points
 - Eliminates damage to screens in high amplitude nodal points.
 - By eliminating hot spots on the screen we can increase power to the entire screen and improve the rate of material processing.
 - Fully programmable power and modulation technology
 - Power adjust 1% to 100% (standard power modules in 300 watts, 600 watts, 1200 watts, and up to 20 kW on request)
 - Center Frequency settings (large interval)
 - Pulse Width Modulation Period (Period 10 ms to 1,000 ms)
 - Pulse Width Modulation Ratio (0% to 100%)
 - MMM special modulation settings (fast sweeping, sweeping, & tracking)
 - Programmable features allows greater processing flexibility with all kinds of powders and especially sticky and difficult powders.
 - MMM technology will drive most any shape (round, oval, square, rectangle) sieve or screen, even large mass systems.
 - MMM converters may be connected to most any efficient point on the sieve/screen or frame.
 - A field adjustable resonant frequency option allows rings to be built without specific tuning. This means ring resonators designs can be simplified and produced at lower cost.
 - The MMM system can adapt to most any other manufacturers installed sieving transducer and screen allowing a simple field upgrade.

MMM Sieving in Action

- ❑ New Wideband Ultrasonic Effects
- ❑ Faster Sieving
- ❑ Less Binding and Prevents Blinding (Self Cleaning)
- ❑ Less damage to Sieve Screen
- ❑ No Standing Waves
- ❑ **See the movies: RIGHT**



CLICK & PLAY

More of MMM Sieving in Action



Sticky powder-food

Fast sieving

Easy de-blinding

Any screen size

Any screen geometry

Permanently clean

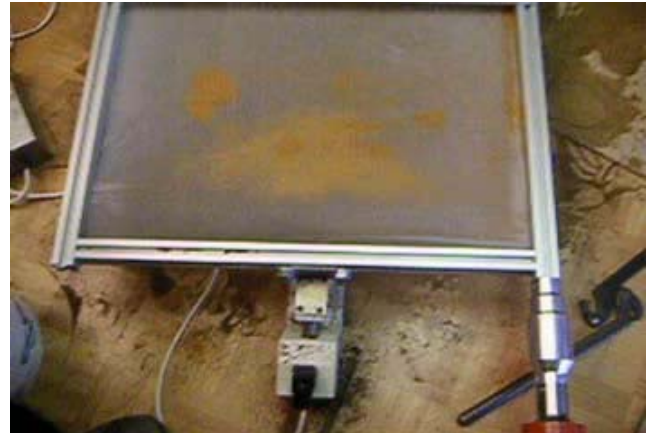

MMM will realize most difficult and most demanding sieving where any other in the same field is failing.

More of MMM Sieving in Action



CLICK & PLAY



Sieving screens and converters from **our** worldwide **competitors** are operating much better driven by MMM sieving generators.

Any existing screen and any converter can be driven by universal MMM generator.
MMM compatible to all: Just replace your existing generator with MMM.

Any imaginable sieving screen-shape can be efficiently driven by MMM.

Easy avoid all existing patents and make your sieving equipment with our MMM...

Sieving Screens

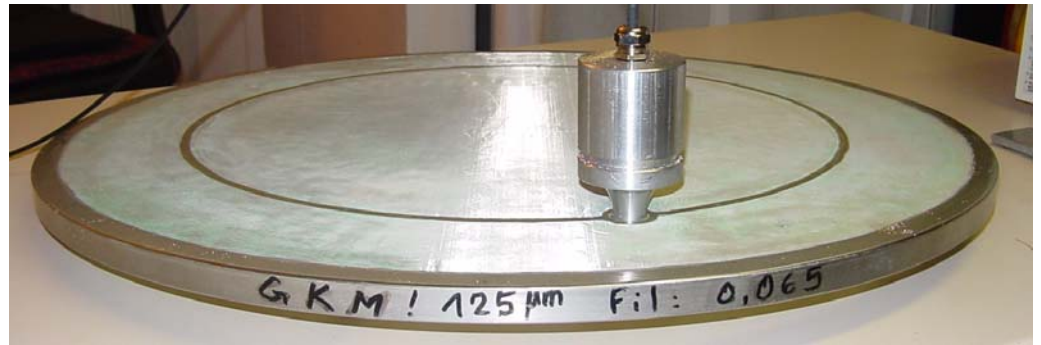

MMM for Any Size,
Any Shape,
Any Powder



MMM Sieving - Developments

- Drive New Screen Shapes:
 - Square, Rectangle, Oval
 - Barrels, Half-Barrels
- Liquid Sieving or Filtering
- Multi-Transducers
- Flexible Transducer Placement
- Long Wave-guide Driving
- Any Power for Any Size Screen
- **MMM Frequency Agility:** The same DSP technology that allows the MMM generator to be adaptable to any shape sieve or screen is used to provide unprecedented frequency agility. Other fixed-frequency systems are driving the total acoustic system (converter & screen frame) at a frequency optimized for the converter without full consideration of how the screen frame is changing the whole system resonant frequency. Rather than fighting physics our systems are adapting to the new resonant frequency when an un-tuned mass (the screen frame) is attached to a converter. Normal MMM factory options allow for system resonant frequency adjustment within a 12 kHz window (e.g. 25 kHz to 37 kHz). Such agility allows fine tuning for optimum performance.
- **MMM Converter Agility:** Additional system flexibility is provided through adaptive inductive compensation that allows attachment and efficient driving of converters from other manufacturers. This allows us to improve existing ultrasonic systems through a simple MMM retrofit.

Sieving Converters Developments

- ❑ New Converter Housings
- ❑ Integrated Front Mass Options
- ❑ Explosion Proof Housing/Cable
- ❑ Explosion Proof Wave Guides...



Sieving Converters Housing Concepts

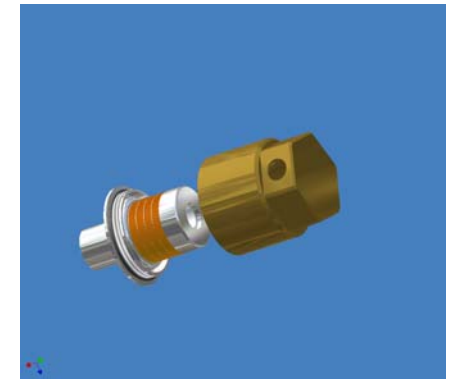
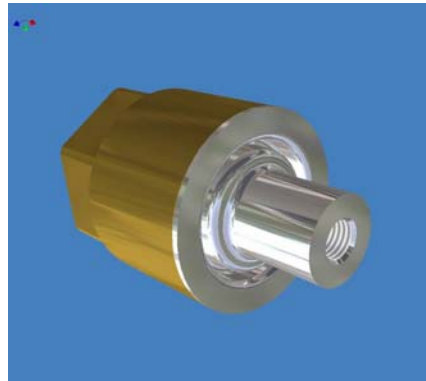
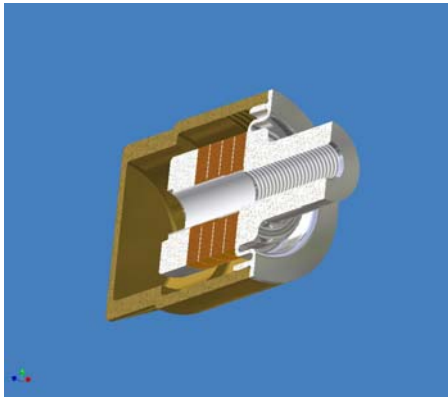
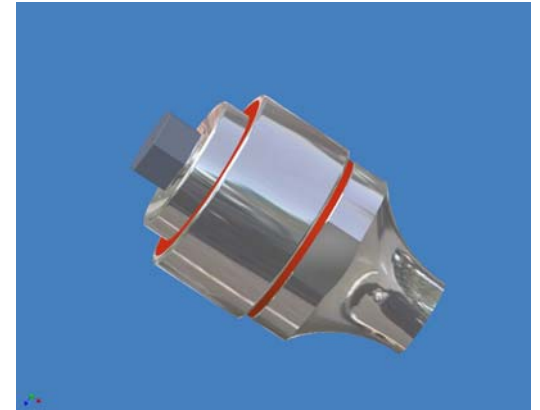
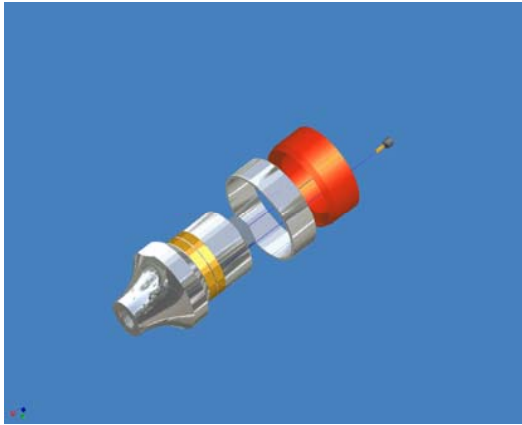

MMM Sieving/Powder Related Applications

- ❑ Sieving Applications:
 - ❑ MMM bath for pre-assembly screen fabric washing
 - ❑ MMM bath for assembled screen washing
- ❑ Powder Applications:
 - ❑ Powder Washing in MMM Bath
 - ❑ Powder Formation in MMM Bath
 - ❑ Powders Compacting
 - ❑ Powder Transport in Pipe or Tray using MMM
 - ❑ Prevents clumping (agglomeration) of powders
 - ❑ Prevents powder build-up at joints



(12) **EUROPEAN PATENT APPLICATION**

(43) Date of publication: **11.09.2002 Bulletin 2002/37** (51) Int Cl.7: **B06B 1/02**

(21) Application number: **01810227.7**

(22) Date of filing: **05.03.2001**

(84) Designated Contracting States:
AT BE CH CY DE DK ES FI FR GB GR IE IT LI LU
MC NL PT SE TR
 Designated Extension States:
AL LT LV MK RO SI

(71) Applicant: **Miodrag Prokic**
2400 Le Locle (CH)

(72) Inventor: **Miodrag Prokic**
2400 Le Locle (CH)

(54) **Multifrequency ultrasonic structural actuators**

(57) The propagation of ultrasonic energy in arbitrary shaped solid structures (D), heavy and very-thick-walls metal containers, pressurized reservoirs, very-thick metal-walls autoclaves, in different mechanical oscillating structures and systems,... is realized using a novel ultrasonic structural, multifrequency actuator (including very particular multifrequency ultrasonic power supply, also the subject of this invention), able to initiate ringing and relaxing, multimode mechanical oscillations (harmonics and sub harmonics) in any heavy-duty, bulky and rigid system, producing pulse-repetitive, phase, frequency and amplitude-modulated bulk-wave-excitation (covering and sweeping extremely large frequency area). Such ultrasonic driving is creating uniform and homogenous distribution of acoustical activity on a surface and inside of the vibrating system, while avoiding creation of stationary and standing waves structure, making that the complete vibrating system is fully agitated. Multifrequency ultrasonic structural actuator is

ideal for agitating arbitrary distant and arbitrary shaped liquid and solid masses placed in different open or pressurized vessels, containers, autoclaves, reservoirs and pipes, transferring vibrations via wave-guide solid rod fixed between the transducer and a loading mass (where loading mass presents an oscillating body, and/or oscillating vessel, autoclave, container...). This invention presents an extension and continuation of the previous patent, originating from the same Author/Inventor (see 1 060 789 A1), explaining the additional aspects of particular electronics necessary to drive ultrasonic transducers in a multifrequency and multi-mode oscillating regime/s, while keeping high efficiency of electric and ultrasonic energy transfer and/or transformation. Fields of possible applications related to this invention are: Ultrasonic Cleaning, Welding, Material Processing, Sonochemistry, Liquid Metals treatment, Atomization, Materials Testing, Aging and Stress Release, Homogenization, Process Industry, etc.

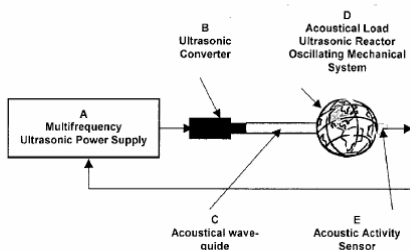

Fig. 1 Block Diagram of a Multifrequency Structural Actuator

MMM (Modulated, Multimode, Multifrequency) ultrasonic generators utilize a new and proprietary technology capable of stimulating wideband sonic and ultrasonic energy, ranging in frequency from infrasonic up to the MHz domain, that propagates through arbitrary shaped solid structures. Such industrial structures may include heavy and thick walled metal containers, pressurized reservoirs, very thick metal walled autoclaves, extruder heads, extruder chambers, mold tools, casting tools, large mixing & cutting probes, various solid mechanical structures, contained liquids, sieving screens and ultrasonic cleaning systems.



MPI Interconsulting
ULTRASONICS - SONOCHEMISTRY - INNOVATION

MMM Seeds & Powders Processing

Main Web Site: <http://www.mpi-ultrasonics.com>

Download Server: <http://mastersonic.com>

Email: mpi@bluewin.ch

Applications

- **Powders and Seeds agitation, mixing, sieving, mass-separation and screening.**
- **Ultrasound is an excellent method of agitating powders, seeds and fluids. While this is known technology we are specializing in development of ultrasonic systems that allow this technology to move from the lab bench or small systems to high volume industrial applications. Based on our proprietary MMM ultrasonic generator technology we have the capability to make large arbitrary shaped (un-tuned) mechanical elements vibrate at ultrasonic frequencies. Normal ultrasonic generator systems cannot make the transition because they rely on carefully tuned mechanical elements of fixed size and shape that limit the scope of their use large scale applications. Our MMM systems allow us to make a wide range of agitating and atomizing elements.**
- **Industrial fluids atomizers & gas mixing (air conditioning, semiconductor technologies...)**
- **Water & fuel atomizers**
- **Liquid alloys atomizers & solder atomizers**
- **Incineration of waste and dangerous liquids by atomizing**
- **Large volume humidifiers & dust removal**
- **Air and water filtering, purification, decontamination & sterilization (nuclear, included)**
- **Micro-encapsulation, coating, surface impregnation**
- **Food and Pharmaceutical applications (surface decontamination)**
- **Electrochemistry & Sonochemistry process integration (nano technologies)**

Powder Agitator in Action

(movie files)



Fine Powder Agitation



Water atomizing

Seeds Agitator in Action

(movie file)

